



KRAMER
MOTORCYCLES

OWNER'S MANUAL
GP2-890R

(2020-23 Model Years)

Introduction

Dear Krämer Customer,

We want to congratulate you on purchasing a Krämer GP2-890R series motorcycle. The GP2-890R is the next level and the logical expansion of the Krämer Motorcycles portfolio. Like the strong "HKR EVO2-690" single, the two-cylinder model was developed and built exclusively for use on the racetrack. With 130 hp and 100 Nm of torque and a weight of only 309 lbs (140 kg), the GP2-890R stands for spectacular riding dynamics without overwhelming the rider. Ideal for the most intense enjoyment on the racetrack - and for hunting lap times!

This manual will serve as a guide to keeping your GP2-890R in race-ready shape.

If you have any questions concerning the operation or maintenance of your motorcycle, please consult your Krämer dealer.

THIS VEHICLE IS SOLD AS IS, NO WARRANTY.



KRÄMER MOTORCYCLES U.S.A.,
Sales ■ Customer Service ■ Parts

114 1st Avenue West,
 West Fargo, ND, 58078
 (701) 367-2258

support@kramer motorcyclesusa.com
 www.kramer motorcyclesusa.com

© 2022 Krämer Motorcycles U.S.A.
 All right reserved.

About This Manual

Use this manual as a guide for proper procedures for this motorcycle's basic operation, inspection, and maintenance. This manual is intended for professional service technicians and those knowledgeable about appropriate safety training and safe shop practices.

All information, directions, photographs, and specifications included in this manual are based on the most current information at the time of publication. Krämer Motorcycles accepts no liability for delivery options, deviations from illustrations and descriptions, misprints, or other errors. Krämer Motorcycles reserves the right to make changes at any time without notice or obligation.

This motorcycle is to be raced on a closed course only. Krämer Motorcycles & Krämer Motorcycles USA are not liable for any injury to riders, mechanics, public, and any damage to the vehicle or property.

This manual is for the following models:

2020-22 Krämer GP2-890R

Version: GP2-890R-2023-4-17

Enter the serial numbers of your vehicle:

Dealer's Stamp

Vehicle identification number

Engine number

Table of Contents

INTRODUCTION

ABOUT THIS MANUAL

USAGE AND SETUP

Identification / Serial Numbers	4
Reference Views of Vehicle	4
Serial Numbers	4
Operating Components	4
Control Components	5
Start Up Procedure	5
Shut Down Procedure	5
Vehicle Break-in Procedure	6
Pre-Ride Inspection	6
Post-Race Service	6
Post-Crash Inspection	6
Transporting / Loading	7
Raising the Motorcycle on Lift Stands	7
Storage	7

MAINTENANCE / SERVICE

Service Schedule	8
Checking the Engine Oil Level	8
Changing the Engine Oil & Filter, and Cleaning the Oil Screens	8
Chain Cleaning / Lubrication	9
Checking the Chain Tension	9
Adjusting the Chain Tension / Rear Axle Alignment	9
Fuel Filler Cap	10
Air Filter Servicing	10

ENGINE

Repairs	11
Recommended Engine Maintenance	11
Throttle Response Modes	11
Engine Braking Modes	11
Pit Limiter Button	11

COOLING SYSTEM

Checking the Coolant Level	12
Draining the Coolant	12
Filling/Bleeding the Cooling System	12

CHASSIS

Handlebar Adjustment	13
Steering Damper Setup	13
Seat/Tank Height Adjustment	13
Bodywork Removal	14
Bodywork Installation	14
Fuel Tank Draining Procedure	15
Fuel Tank Removal/Installation	15
Clutch Lever Free Play and Reach Distance	16
Front Brake Lever Response and Travel Distance	16
Rearset Setup	17
Adjusting the Foot Pegs	17
Rear Brake Lever Adjustment	17
Shift Lever Height Adjustment	17

BRAKE SYSTEM

Brake Inspection	18
Brake Bleeding	18
Changing the Brake Pads	19

SUSPENSION

Suspension Inspection	20
Checking the Steering Head Bearing Play	20
Adjusting the Steering Head Bearing Play	20
Changing the Fork Offset	21
Fork Suspension Settings	22
Adjusting Spring Preload	22
Adjusting Compression Damping	22
Adjusting Rebound Damping	22
Fork Specifications	22
Rear Shock Suspension Settings	23
Adjusting the Spring Preload	23
Adjusting Compression Damping	23
Adjusting Rebound Damping	23
Shock Absorber Specifications	23

WHEELS

Front Wheel Removal	24
Front Wheel Installation	24
Rear Wheel Removal	25
Rear Wheel Installation	25

ELECTRICAL

Tail light Operation	25
Charging the Tail light	25
Fuses	26
Battery	26
Powered Accessory Leads	26
Service Schedule	27

TECHNICAL DATA

GP2 890-R Specifications	28
Fluid Capacities	28
Engine Specifications	28
Electrical System	28
Engine Torque Chart	29
Chassis Torque Chart	30
Safety Wire	30
AIM Compact MXS 1.2 Dash Logger	31
Dash Logger Indicators Overview	31
Dash Logger Menu Configuration Settings	32
Set Date and Time	32
Set Backlight	32
Set Video Input	32
Lap Time Setup	33
Counters Management	33
GPS & Tracks	33
Wi-Fi Management	34
System Info	34
GPS Search	34
Sampled Data Recall	35
Pit Limiter Indicator	35

Usage and Setup

Identification / Serial Numbers

Reference Views of Vehicle

NOTE: Instructions, such as right-hand (R.H.) side and left-hand(L.H.) side are from rider position.

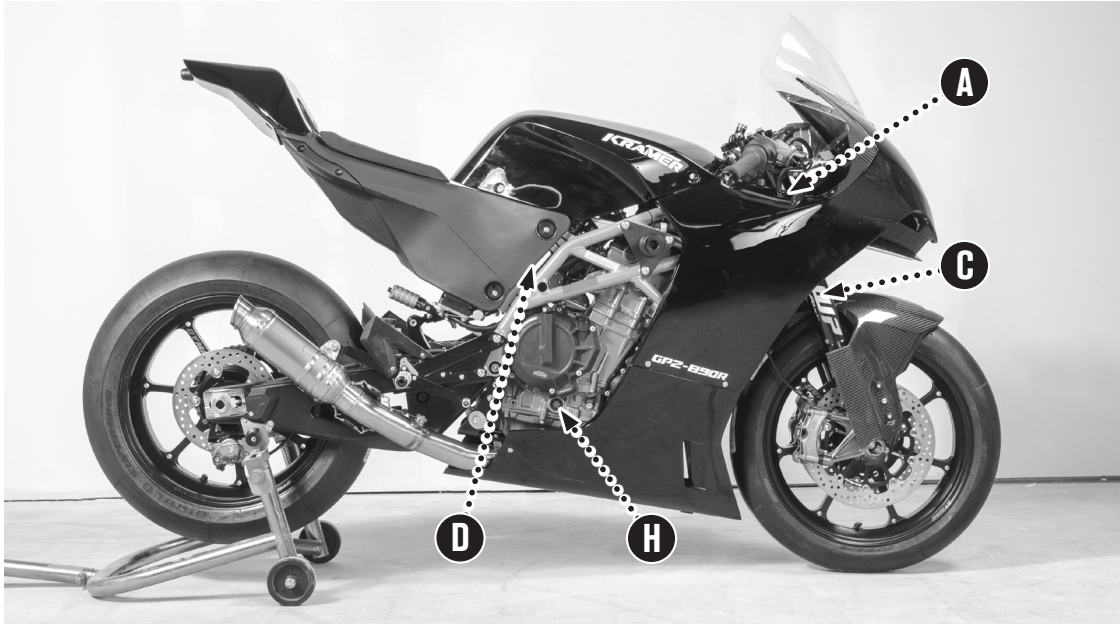

Right Side View

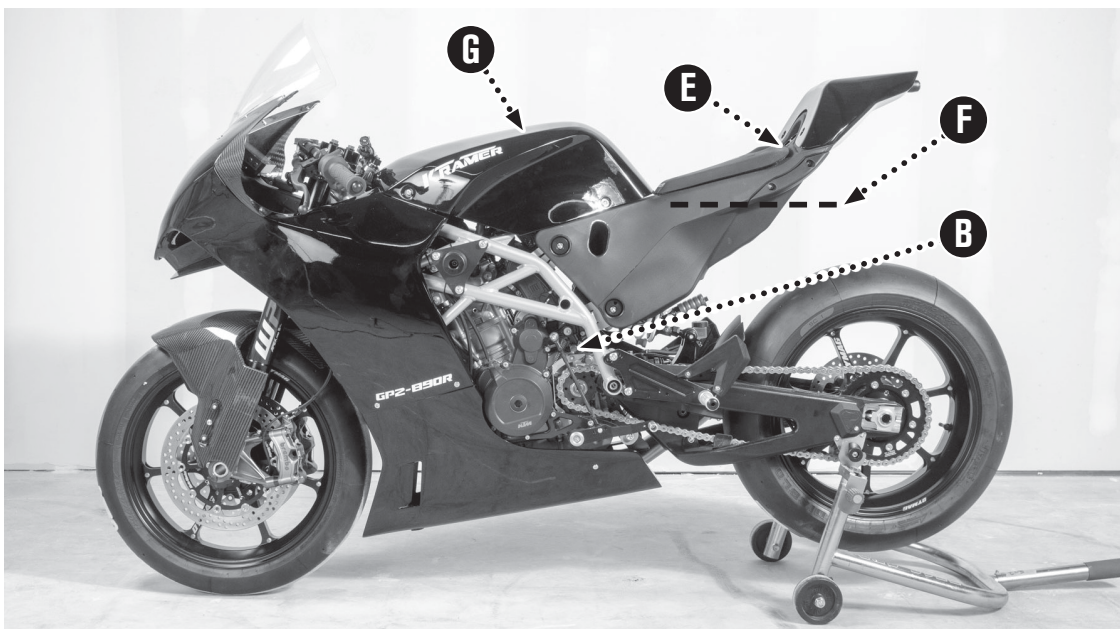

Left Side View

Serial Numbers

- A** Chassis S/N – R.H. side steering head.
- B** Engine S/N – L.H. side of the engine above the sprocket.
- C** Fork S/N – inside the axle clamp.
- D** Shock S/N – top section of shock.

Operating Components

- E** Fuel Fill
- F** Recommended Fuel Fill Amount for Racing (9.5 L or 2.5 US gal). On translucent tanks the fuel will show at this level.
- G** Intake Cover/Air Filter Box
- H** Oil Level Check

Control Components

Hand Controls

- | | |
|---|----------------------------|
| A Speedometer/
Tachometer/Information
Control Center | G Run/Stop Switch |
| B Ignition Switch
(behind fairing support) | H Start Button |
| C Clutch Lever | I Front Brake Lever |
| D Throttle Response | J Throttle |
| E Engine Braking Effect | |
| F Pit Limiter | |

Foot Controls

- | |
|---------------------------|
| K Shift Lever |
| L Rear Brake Lever |

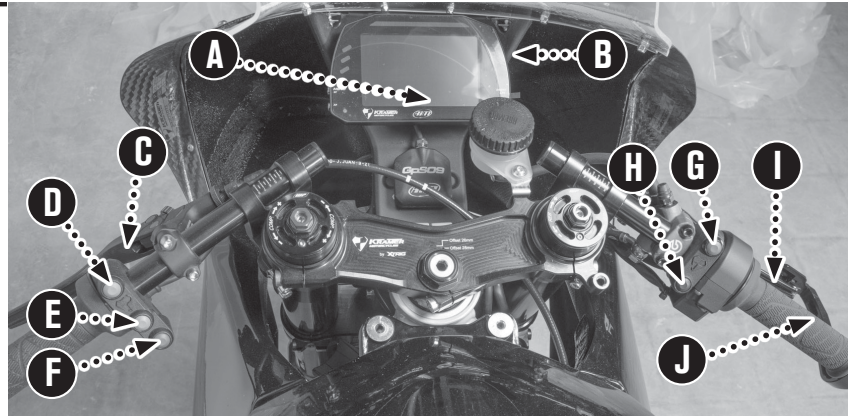

Hand Controls

Start Up Procedure

1. Toggle the ignition switch **B**, located on the back side of speedometer/fairing support, to the ON position (Wait 5 secs for fuel pump to pressurize)
2. Press START button **H**

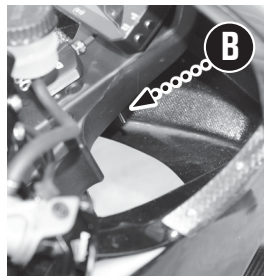

Ignition Switch

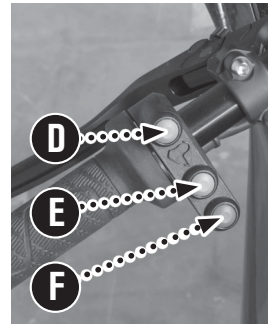

Engine Performance Controls

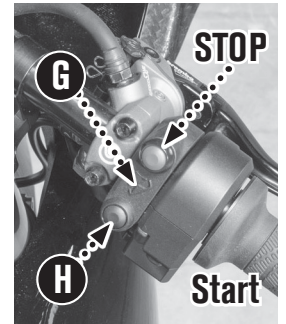

Start/Stop Switch

Shut Down Procedure

1. Press the Run/Stop Switch **G**
2. Toggle ignition switch **B** to OFF position

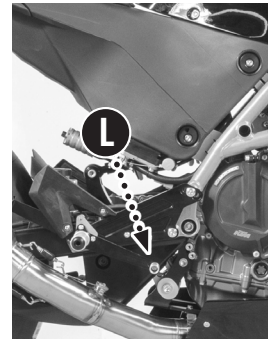

Rear Brake Lever

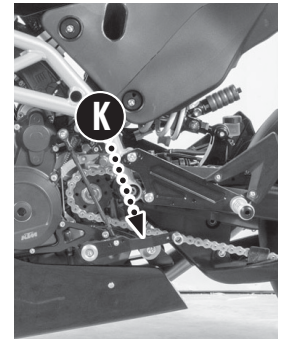

Shift Lever

Vehicle Break-in Procedure

Following the first outing (15-20 minutes):

- Screws should be checked for the correct torque [(See pg. 30)] and general condition.
- Bleed the front brakes. [(See pg. 18)]

For the first 100 km (62 miles)

- Do not exceed 70% of full brake pressure.

For the first 200 km (124 miles)

- Do not exceed 7500 rpm.

After 2 hours of run time

- Change engine oil and filters.

Pre-Ride Inspection

- **Check engine oil level** - Oil level to be centered between the “maximum” and “minimum” indicators. [(See pg. 8)]
- **Check coolant level** - Coolant should be visible at the bottom of the radiator fill fitting when the radiator cap is removed. [(See pg. 12)]
- **Check tire pressure** - Set to 2.21 Bar (32 PSI) in the front tire and 1.65 Bar (24 PSI) in

the rear. Tire pressure may vary by tire type. Tire warmers are recommended for most race tires.

- **Check fuel level** - Recommended race fuel amount is approximately 9.5 L (2.5 US gal). On translucent tanks the level will be even with the Intake Cover/Air Filter Box mounting screw. [(See pg. 4)] Maximum fuel capacity is 16 L (4.2 US gal.)
- **Check the chain tension** [(See pg. 9)]
- **Inspect suspension components** (forks, rear shock, linkages) for leaks, excessive wear, or any looseness. [(See pg. 20)]
- **Let the engine run up to 176°F (80°C)**, during which the throttle should not be turned.



CAUTION!

Danger of scalding

During motorcycle operation, the coolant gets very hot and is under pressure.

– Do not open the radiator or other cooling system components if the engine or the cooling system are at operating temperature.

– Allow the cooling system to cool down before inspecting or servicing.

Post-Race Service

After each race weekend or 5 hours ride time, whichever comes first:

- Remove and clean the fairing (except front fender) [(See pg. 14)]
- Thoroughly clean the motorcycle (frame, tank, swingarm, fenders, and rims)
- Check the visual condition and torque of each screw [(See pg. 30)]
- Replace engine oil and oil filters [(See pg. 8)]
- Bleed the front brake, rear brake, and the clutch [(See pg. 18)]
- Perform chain maintenance [(See pg. 9)]

Post-Crash Inspection

1. Remove the entire fairing (including the Intake Cover/Air Filter Box). [(See pg. 14)]
2. Disassemble the air filter box and check for any blemishes/dirt within the air filter box and air filter. [(See pg. 10)]
3. Thoroughly clean the fairing and all exposed areas of the motorcycle while checking for damage.
4. Replace any damaged parts with new ones.
5. Inspect Suspension. [(See pg. 20)]
Loosen the front axle pinch bolts and bottom triple clamp bolts. Compress the front forks several times, to insure functionality, before re-tightening every bolt to the appropriate torque specifications.
6. Clean and lubricate the chain. [(See pg. 9)]
7. Check the coolant level [(See pg. 12)]
8. Check the engine oil level [(See pg. 8)].
– After crash the oil level may appear low, start engine, run for 15 seconds, stop engine, and check level.
– and fill as necessary.

Typical crash damage to inspect:

- Front forks
- Handlebars
- Crash pads
- Crash pad frame mounting plates
- Rearset
- Shift & brake linkages
- Debris trapped between the linkages

Transporting / Loading

NOTE: Use wheel chock to stabilize front wheel.

Recommended Tie-Down Points

- FRONT:** Attach a soft-tie loop straps on the lower triple tree. Lead the loop forward out the lower front fairing **A** attaching to the tie-down straps secured to a solid mounting point in the transport vehicle.
 - Use one on each side of the motorcycle.
 - Tighten straps enough to tension the front forks partially, being careful that the forks are not compressed completely.
- REAR:** Attach a tie-down strap around the rear wheel **B** and tighten the strap rearward, preventing the motorcycle from rolling forward.



Raising the Motorcycle on Lift Stands

NOTE: Park the motorcycle on a level, firm surface.



CAUTION!

Don't park the motorcycle in direct sun.

– The windshield can amplify the sun's radiant heat.

▪ Lifting the rear

- The motorcycle is equipped with lifting spools **C**. Insert the lift stand into the groove of the lifting spools.
- Press down on the rear handle of the stand raising the rear of the motorcycle.

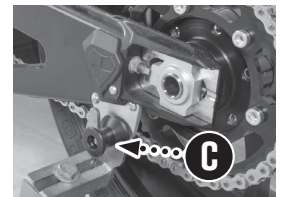

▪ Lifting the front (raise rear first)

- The motorcycle is equipped to lift the front with a pin-style stand.
- Position the pin of the lift stand into the hole on the lower triple clamp **D** of the front forks.
- Press down on the front handle of the stand, raising the front of the motorcycle.

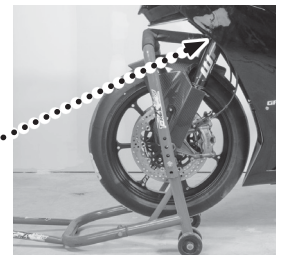
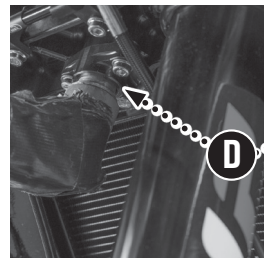

Storage

To store the motorcycle for an extended period, take the following actions.

Before storing the motorcycle:

- Inspect all parts for function and wear.
- If repairs or replacements are necessary, perform the service before storing.

Preparing for Storage:

- Drain fuel tank **E** empty. See "Fuel Tank Draining Procedure" on page 15.
- Clean the motorcycle.

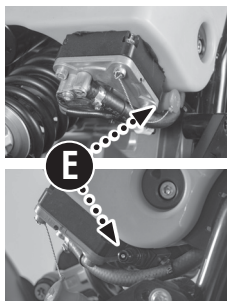

Fuel Tank Drain - R.H.

- Change the engine oil and the oil filter. Clean the oil screens.
- Check the coolant level and service if necessary with Engine Ice brand coolant. If the storage area will reach temperatures below 0°C (32°F) drain the coolant completely.
- Check the tire pressure.
- Remove the battery from the motorcycle. Store in a safe, warm area, 0°-30°C (32°-85°F), out of direct sun. Keep connected to a lithium rated float charger.
- Store motorcycle in a dry location with a stable temperature.
- Raise the motorcycle on the front, and rear lifting stands.

Removing from Storage

- Fill coolant, if drained for freezing temperature storage conditions.
- Install a fully charged battery.
- Perform pre-ride checks.
- Lower the motorcycle from the lifting stands.
- Take for a test ride.

Maintenance / Service

Service Schedule

For a detailed listing of service schedule see the chart [Pg. 27.]

Checking the Engine Oil Level

Check the engine oil level at normal engine operating temperature.

1. Stand the motorcycle upright on a level surface.
2. Start engine and warm to normal operating temperature. (Turn off the engine, wait one minute before checking the level.)
3. Check the engine oil in the sight glass window **A**. The level must be between the lower and upper markings beside the window.
4. If needed, add oil, at oil filler **B**, to specified level.

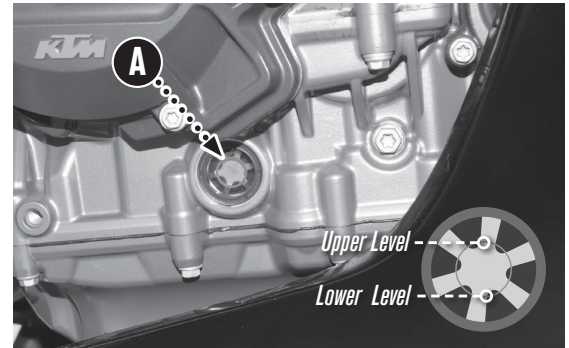

Oil Level Window (R.H. side of engine)

Changing the Engine Oil & Filter, and Cleaning the Oil Screens

Oil Draining

1. Raise the rear of the motorcycle on a rear lift stand. [See pg. 7]
2. Remove the front fairing. [See pg. 13]
3. Start the engine and warm it to normal operating temperature.
4. Remove the safety wire.
5. Place a drain container under the engine
6. Remove the oil filler cap **B** from the clutch cover.
7. Remove the oil drain plugs **C** along with the magnets, the o-rings, and the oil screens.
8. Completely drain the engine oil.
9. **Inspect the magnets, o-rings, and the oil screens** for any metal shavings, and thoroughly clean the plugs, screens, and magnets.

5. Coat the o-ring with oil, position the oil filter cover, and reinstall the cover screws.
6. Torque the cover screws – 6 Nm (4.4 lb-ft).

Oil Changing

1. Drain the oil
2. Change the oil filter
3. Install the oil drain plugs **C**, the magnets, the o-rings, and the oil screens.
4. Tighten the oil screen plugs **C** – 15 Nm (11.1 lb-ft).
5. Fill up engine oil at filler **B** – 2.8 L. (3 qt.) of SAE 15W-50 oil.
6. Install and tighten the filler plug **B**.
7. Let the engine run for approx. 30 seconds, check thoroughly for leaks.
8. Check the engine oil level **A**.
9. Rewire the locking safety wire.

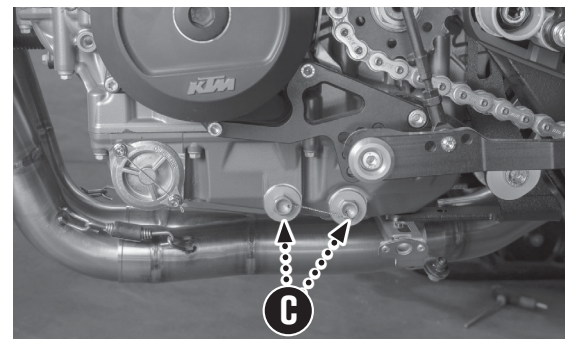

Oil Filter, Drain Plugs with Screens and Magnets – Left Side of Engine

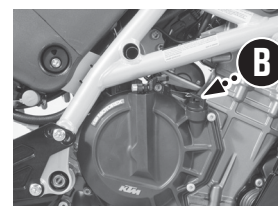

Oil Filler

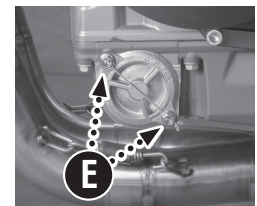

Oil Filter Screws

Oil Filter Changing

1. Remove the screws from the oil filter cover **E**, and remove cover with the o-ring.
2. Pull out the filter. Allow the remaining engine oil to drain.
3. Thoroughly clean the parts and sealing surfaces.
4. Insert the new oil filter.

! Safety wire oil drain plugs **C**, oil filter cover **E**, and filler plug **B**

Chain Cleaning / Lubrication

1. Raise the rear of the motorcycle on a lift stand. [See pg. 7]
2. Check that the shift lever is in neutral.
3. Spray chain cleaner on the chain while turning the rear tire. Rotate the wheel until the entire chain is sprayed with the cleaner.
4. Let the cleaner soak for approximately 5 minutes.
5. Remove excess cleaner – using a fabric rag (not a paper towel), wipe the chain while rotating the wheel several turns, making sure that the entire chain has run through the rag several times.
6. Let the chain dry to the touch before spraying lubricant.
7. Apply chain lubricant – Carefully spray the lubricant in the front of the chain tunnel in the swingarm **A**, with the spray nozzle facing downwards into the inside of the chain links. Rotate the rear wheel until the entire chain is lubricated.
8. Clean the area surrounding the chain – when completing the cleaning and lubrication process, check and clean any residues of any liquids on the rear rim, tire, brake disc, and swingarm.
9. Check the chain tension. [See pg. 9]



CAUTION! Pinch Hazard

Be careful not to pinch fingers between chain and sprockets.



Spray Chain Cleaner



Wipe Cleaner Dry

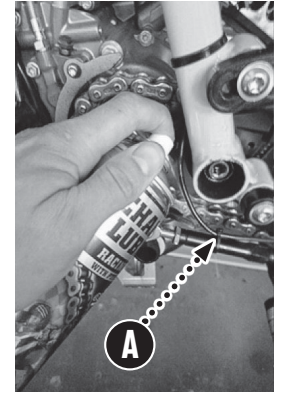

Spray Chain Lubricant

Checking the Chain Tension

1. Raise the rear of the motorcycle on a lift stand. [(See pg. 7)]
2. Check that the shift lever is in neutral.
3. Measure at the chain mid-point between sprockets. The specified vertical chain tension **F** is 30-35 mm (1.18-1.38 in.).

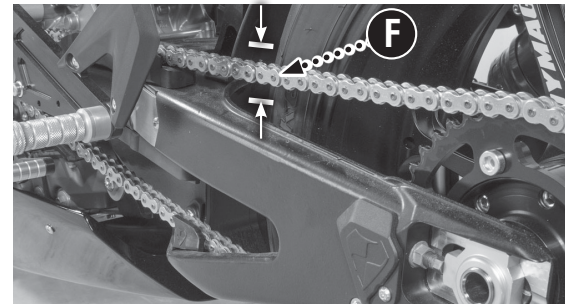

Chain tension measurement

Adjusting the Chain Tension / Rear Axle Alignment

1. Raise the rear of the motorcycle on a lift stand. [(See pg. 7)]
2. Check that the shift lever is in neutral.
3. Loosen the jam nuts **B** on the adjuster screws on both sides of the swingarm.
4. Loosen the axle nut **C**.
5. Turn the adjuster screw **D** until the vertical chain tension **F** is 30-35 mm (1.18-1.38 in.). Measure at the chain mid-point.
6. On both sides, measure and compare the distance **E** between the swingarm's rear edge and the edge of the adjuster blocks. Fine-tune the adjuster screws until the distance is equal (+/- 1 mm) on both sides.
7. Tighten the adjuster screw jam nuts **B**.
8. Check that the adjuster blocks are fully seated forward against the adjuster screws.
9. While applying forward pressure on the wheel, tighten the axle nut to specified torque – 100 Nm (73.7 ft-lb).

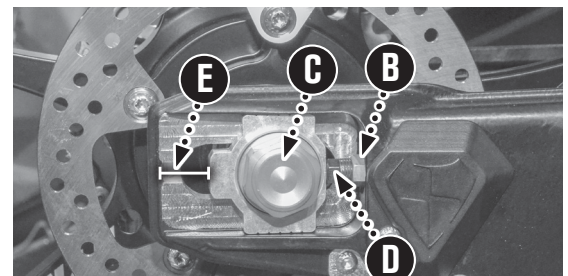

Right side of swingarm

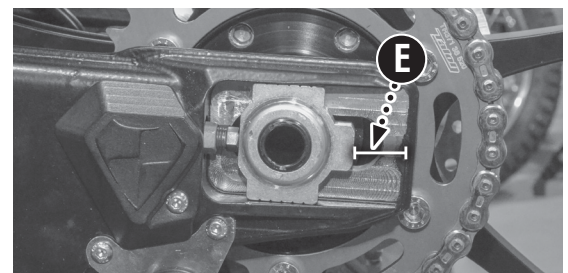

Left side of swingarm

Fuel Filler Cap

Open the Fuel Filler Cap

1. Push down on the cap lever **A**.
2. Rotate it counter-clockwise 1/4-turn.
3. Lift out the cap.

Close the Fuel Filler Cap

1. Line up the cap retainer pins **B** with slots **C** in the filler neck.
2. Rotate it clockwise, approximately 1/4-turn until it clicks.



FIRE HAZARD

Fuel is highly flammable.

The fuel in the fuel tank expands when warm and can escape if overfilled.

- Turn off the engine for refueling
- Do not refuel the vehicle near open flames or lit cigarettes
- Wipe spilled fuel immediately

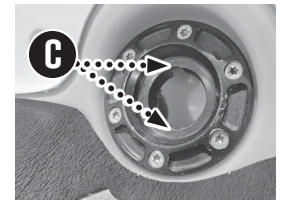
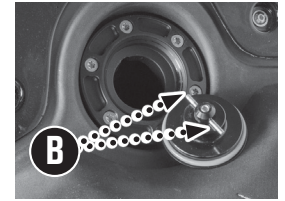
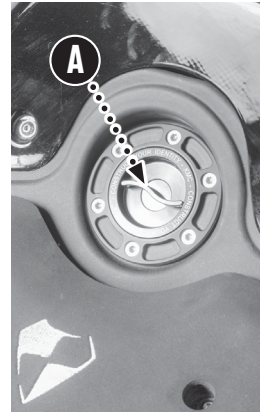

Air Filter Servicing

Removal

1. Remove the Intake Cover/Air Filter Box from the motorcycle ((See pg. 3)).
2. Open the 1/4-turn fasteners **A** at the front and rear of the air filter.
3. Remove the air filter and inspect.
4. Remove the foam air filter from the filter support cage.

Installation

1. Install foam air filter on filter support cage.
2. Grease the air filter rim. (TwinAir BIO Air Filter Sealant)
3. Position the air filter in the air filter box and lock the 1/4-turn fasteners **A** at the front and rear of the air filter.



FOAM AIR FILTER CLEANER AND OIL (RECOMMENDED)

- TwinAir BIO line of cleaner, oil and sealant.
- NOTE: The foam air filter is factory oiled with TwinAir BIO biodegradable oil and sealant which are not compatible with petroleum based filter products. To ensure compatibility and engine protection continue using the TwinAir BIO line on the air filter.

Cleaning the Air Filter.

1. Clean and oil the foam air filter element following directions of the reusable foam air filter service kit. (TwinAir BIO line of cleaner, oil and sealant).
2. Clean the air filter support cage.
3. Clean the air filter box.
4. Clean the intake flange and inspect for damage.
5. Reinstall the air filter.



Air Filter 1/4-Turn Fasteners



Reusable Foam Air Filter



Air Filter Support Cage



REPLACEMENT AIR FILTER

Part #: 300604006
Washable/Reusable Air Filter

Engine

Repairs

Utilize a KTM 890 Duke Repair manual, available from your KTM dealer, to perform more extensive repairs of the Krämer GP2-890R.

Recommended Engine Maintenance

- See Service Schedule on Pg. 27

Throttle Response Modes

- **Sun Symbol** – Extremely direct response
 - **Rain Symbol** – Gentle response
1. Throttle response modes are changed with button **B** on L.H. handlebar.
 2. Modes can be changed while riding when the throttle grip is closed.
 3. A pre-setting **C** can be set while riding. The pre-setting will become active when the throttle grip is closed. The active state is shown in section **D**.

Engine Braking Modes

- **Arrow Up** – More engine braking
 - **Arrow Down** – Less engine braking
1. Engine Braking modes are changed with button **E** on L.H. handlebar.
 2. Modes can be changed while riding when the throttle grip is closed.
 3. A pre-setting **F** can be set while riding. The pre-setting will become active when the throttle grip is closed. The active state is shown in section **G**.

Pit Limiter Button

- **NOTE:** The Pit Limit mode limits the speed of the motorcycle.
1. Engage Pit Limit mode by pressing the button **H** on L.H. handlebar. Disengage Pit Limit mode by pressing the button again.
 2. When engaged, the dash logger will display a "PIT LIMITER" message.

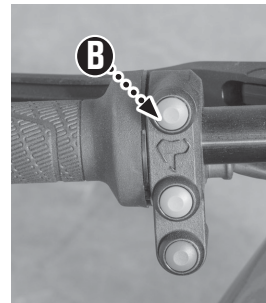

Throttle Response Modes

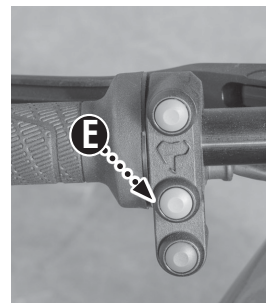
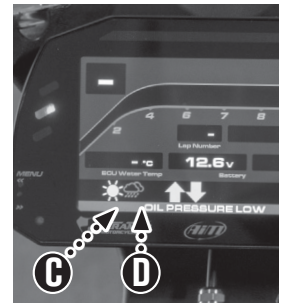

Engine Braking Modes

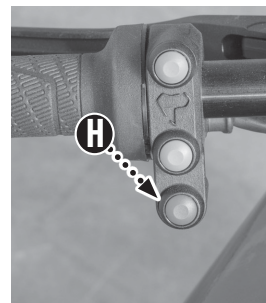

Pit Limiter Button



Cooling System

Checking the Coolant Level

1. With the engine cold, position the motorcycle on a level surface.
2. Remove the front fairing. [(See pg. 14)]
3. Check coolant level of the radiator. Remove radiator cap **B**.
4. Reinstall the radiator cap. Coolant should be visible at the bottom of the radiator fill fitting—35mm (1.38") below the upper edge of filler neck **C**.

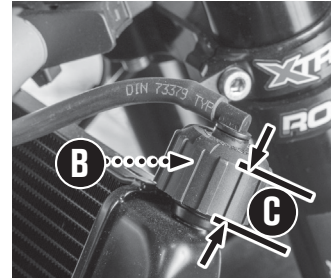

Radiator Fluid Level

Draining the Coolant

1. With the engine cold, position the motorcycle on a level surface.
2. If it's still in place, remove the front fairing. [(See pg. 14)]
3. Place a suitable container under the engine. Remove the drain screw **D**.
4. Remove the radiator cap.
5. Completely drain the coolant.
6. Insert and tighten the drain screw **D** with a new seal ring – 15 Nm (11.11 ft-lb).
7. Install the radiator cap.

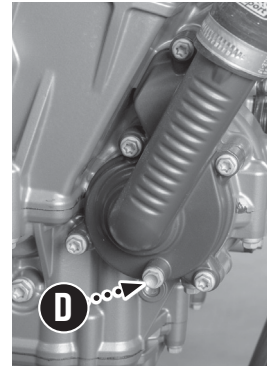

Coolant Drain Plug

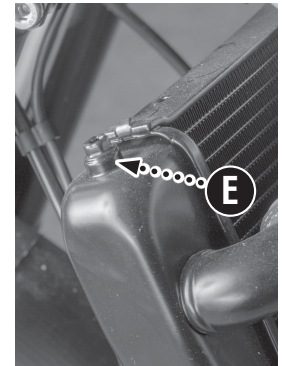

Coolant System Bleed Screw

Filling/Bleeding the Cooling System

1. With the engine cold, remove the radiator cap **B**.
2. Remove the bleeder screw **E**.
3. Tilt the vehicle slightly to the right. Pour in coolant until it emerges without bubbles at the vent hole, and then replace the bleeder screw **E**.
4. Completely fill the radiator with coolant. Install radiator cap.
5. Check the coolant level.
6. Start and run the engine to operating temperature. Turn off the engine.
7. When the engine is cool, check the coolant level in the compensating tank and the radiator. Add coolant if necessary.

Chassis

Handlebar Adjustment

The position of the handlebars is adjustable in both height and angle. Please note that the right and the left handlebar sides mirror each other, and neither should be at a different angle or height.

Height and Angle Adjustment

1. Loosen the clamping screws **C** of the clip-ons on both sides.
2. Adjust the height of the handlebars by sliding up or down on the fork tube. Adjust the angle by rotating around the fork tube. Use the angle marks **D** to ensure that both sides are equal.)
3. Swing handlebars from lock to lock, making sure nothing touches or rubs.
4. Tighten the clamping screws **C** of the clip-ons alternately until the appropriate torque is attained – 10 Nm (7.4 ft-lb).

Width Adjustment (2 positions)

1. Loosen the clamping screws **E** of the clip-ons on both sides.
2. Adjust the width of the handlebars. Read the setting marks at the edge of the window **F**. (Ensure that both sides are equal.)
 - Check the steering for binding and kinked cables or lines.
3. Tighten the clamping screws **E** of the clip-ons alternately until the appropriate torque is attained – 10 Nm (7.4 ft-lb).

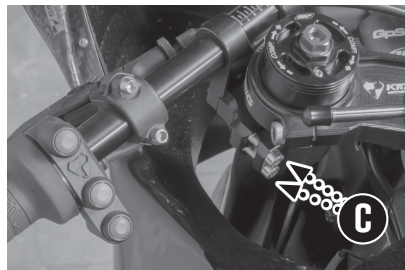

Handlebar Height and Angle Adjustment

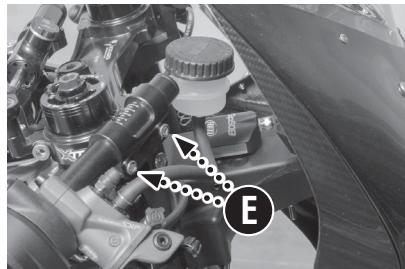
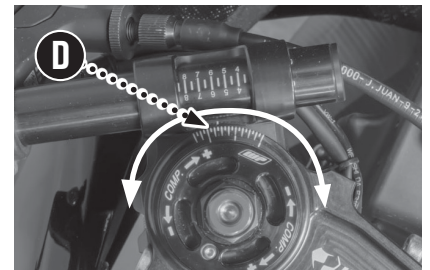

Handlebar Width Adjustment

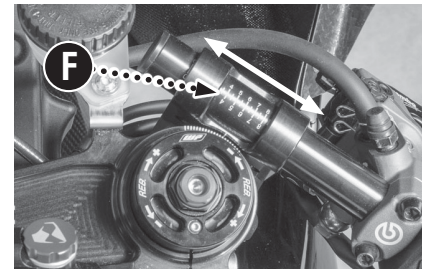

Steering Damper Setup

Setting the steering damper's firmness is dependent on riding style and track characteristics. In high-speed corners, a higher setting may help keep the motorcycle more stable. However, too high of a setting in tight and twisty sections may cost valuable agility and precision.

Adjust Damper Firmness

1. Rotate the adjusting knob **G** clockwise to the last detectable click.
2. Adjust to the desired firmness by turning the adjusting knob counter-clockwise.
 - **The Adjustment Range** is 1-24 clicks. The standard is 12 clicks.

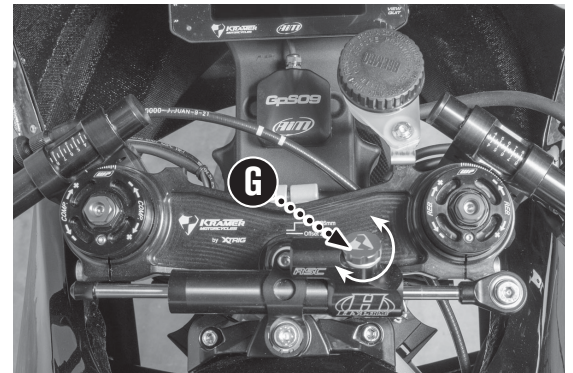

Steering Damper Adjusting Knob

Seat/Tank Height Adjustment

The seat height is adjusted by moving the complete seat/tank unit. The height is adjusted by turning the eccentric tank mounts **B**.

1. Loosen the bottom mount screws **A** on both sides of the tank.
2. Using a 6 mm Allen wrench placed in the triangular hole, turn the eccentric base **B** to the desired seat position.
3. Temporarily tighten the left mounting screw.

4. Remove the right mounting screw, apply blue thread lock*, reinsert and tighten to the appropriate torque – 30 Nm (22.1 ft-lb).
5. Remove the left mounting screw, apply blue thread lock*, reinsert and tighten to the appropriate torque – 30 Nm (22.1 ft-lb).

* Loctite® 243™

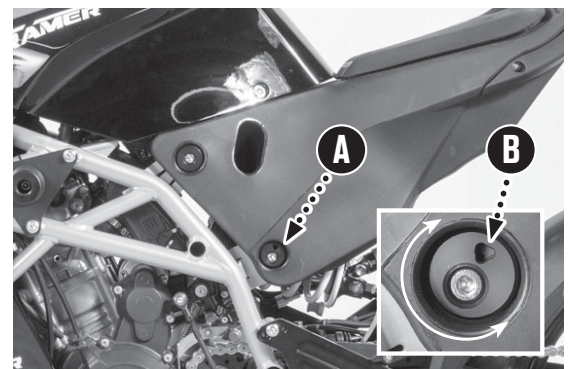

Fuel Tank Mounting/Height Adjustment Screws

Bodywork Removal

Remove the bodywork pieces in the order of appearance. Reinstall the bodywork pieces in reverse order [See below].

Remove Intake Cover/Air Filter Box

1. Remove the two screws **I** holding the steering damper mount.
2. Remove the two screws **E** at the rear of each side.
3. Remove the two 1/4-turn fasteners **C** on each side.
4. Carefully lift the intake cover/air filter box rearward and up.

Remove Front Fender

5. Remove the 1/4-turn fasteners **F** on each side.
6. Spread the fender and remove it forward.

Remove Lower Fairing

7. Remove the two 1/4-turn fasteners **D** on each side.
8. Remove the four 1/4-turn fasteners **E** on each side.
9. Carefully remove the lower fairing.

Remove Upper Fairing

10. Remove the two 1/4-turn fasteners **A** under the windshield.
11. NOTE: If the intake cover/air filter box is not removed, then remove the two 1/4-turn fasteners **C** on each side.
12. Remove the upper fairing by pulling it forward, carefully maneuvering it around the forks.

Remove Tail Cap

13. Remove the two screws **G** under the tail cap.
14. Remove the two screws **H** on top of the tail cap.
15. Slide the tail cap rearward and upward.

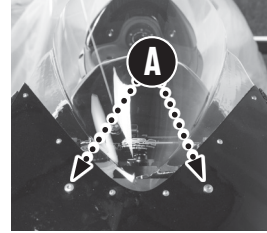

Front Upper Fairing Fastener Locations

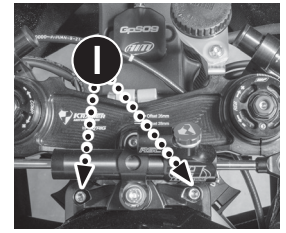

Steering Damper Screws

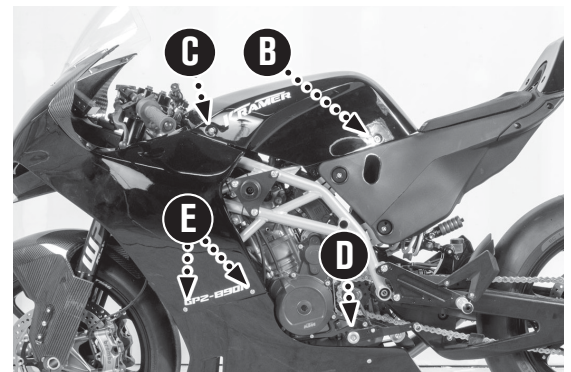
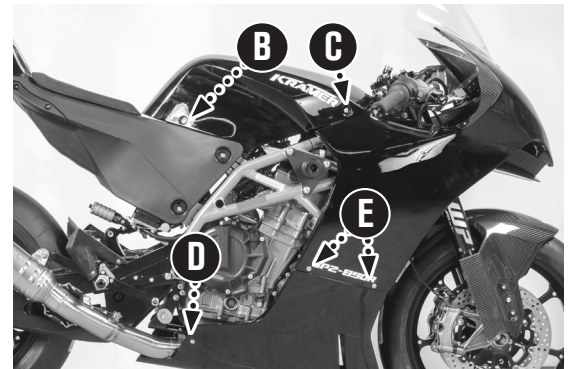

Upper and Lower Fairing Fastener Locations

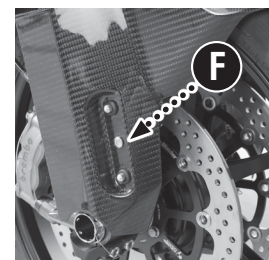

Front Fender Fasteners - R.H.

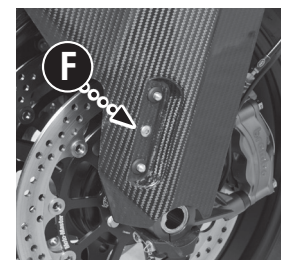

Front Fender Fasteners - L.H.



Tail Cap Fastener Locations

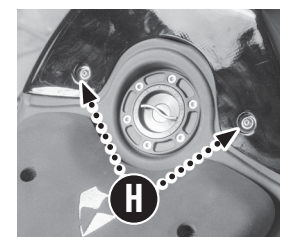

Bodywork Installation

Install bodywork in the order of appearance.



USE BLUE THREAD LOCK* ON ALL THREADED FASTENERS. Apply to the thread inserts not the screw threads.

Install Upper Fairing

1. Turn the handlebar all the way to the left.
2. Install the upper fairing carefully maneuvering around the forks.
3. Install the two 1/4-turn fasteners **A** under the windshield.

Install Front Fender

4. Spread the fender and install it from the front sliding it rearward.
5. Install the two 1/4-turn fasteners **F** – one on each side.

Install Lower Fairing

6. Carefully install the lower fairing.
7. Install the four 1/4-turn fasteners **E** – two on each side.
8. Install the two 1/4-turn fasteners **D** – one on each side.

Install Intake Cover/Air Filter Box

9. Position the Intake Cover/Air Filter Box.
10. Finger-tighten the two screws **B** at the rear of each side.
11. Install the two 1/4-turn fasteners **C** on each side.
12. Install the two screws **I** holding the steering damper mount – 10 Nm (7.4 ft-lb).
13. Torque the two screws **B** at the rear of each side – 6-9 Nm (50-80 in-lb).

NOTE:

Regularly check the tightness of velocity stacks.

Install Tail Cap

14. Slide the tail cap in position.
15. Install the two screws **G** under the tail cap – 5 Nm (44 in-lb).
16. Install the two screws **H** on top of the tail cap – 5 Nm (44 in-lb).

* Loctite®243™

Fuel Tank Draining Procedure



CAUTION! Fire Hazard

Drain the fuel in a well-ventilated area without any open flame or sparks.

Have a fire extinguisher nearby.

Drain and store fuel in an approved fuel container.

NOTE: Before starting the draining procedure, have at the ready a fuel container large enough to hold the amount of fuel remaining in the tank.

1. Remove the fuel cap to allow tank ventilation.
2. Remove the protective red cap **A** from the fuel tank quick-couple drain port **B** on the fuel pump located on the lower right-hand side of the fuel tank.
3. Using the dealer-provided drain hose **C**, slide back the collar of the quick-couple fitting, and place it on the drain port. Fuel will start gravity-draining immediately.
4. When the tank is empty, replace fuel cap.
5. Remove drain hose **C**, clean, and store.
6. Replace the red protective cap **A**.

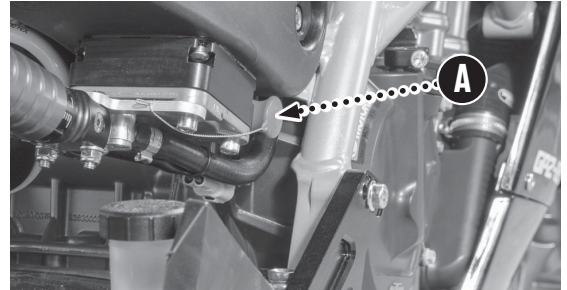

Protective Cap on the Fuel Tank Drain Port

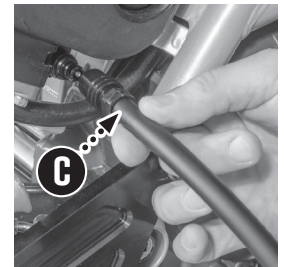
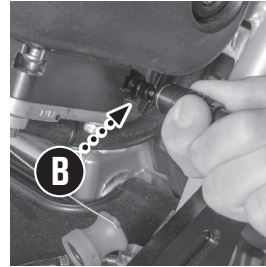

Attaching the Quick-Couple Drain Hose

Fuel Tank Removal/Installation

Removal

1. Remove the air box cover [See pg. 13].
2. Remove the shock adjuster screws **A** and let the adjuster hang to the side.
3. Unplug the fuel pump electrical connector **C**.
4. Remove fuel hose from injection rail.
5. Remove the support bracket screws **E** and the tank mounting screws **F** on both sides.
6. Remove the fuel tank by lifting it towards the rear of the motorcycle.

NOTE:

Regularly check the tightness of velocity stacks.

Installation

7. Position the fuel tank in place.
8. Install and tighten the screws **E** on both sides – 10 Nm (7.4 ft-lb).
9. Install, apply blue thread lock*, and tighten the screws **F** on both sides – 25 Nm (18.4 ft-lb).
10. Plug in the fuel pump electrical connector **C**.
11. Install fuel hose on the injection rail.
12. Mount the shock preload adjuster, install and tighten the shock preload adjuster screws **A** – 10 Nm (7.4 ft-lb)

* Loctite® 243™

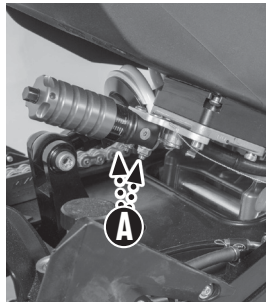

Shock Preload Adjuster Screws



Fuel Pump Connector

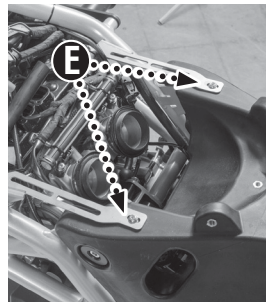

Fuel Tank Support Bracket Screws

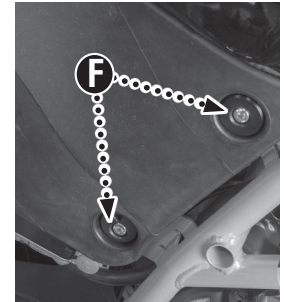

Fuel Tank Mounting Screws

Clutch Lever Free Play and Reach Distance

Checking Clutch Lever Free Play

1. Check the clutch lever for smooth operation
2. Position the handlebar to straight-ahead.
3. Move the lever until resistance is felt, determine the amount of play. 3-5mm is the specified amount of free play.

Adjusting Clutch Lever Free Play

1. Position the handlebar straight ahead.
2. Loosen lock nut **A**.
3. Turn the adjusting barrel **B** to adjust the clutch lever free play. 3-5mm is the specified amount of free play.
4. Tighten the lock nut **A**.

NOTE: Proper free play is important to prevent clutch damage.

- No free play could cause the clutch to slip.
- Too much free play could cause incomplete clutch engagement.

Adjusting Clutch Lever Reach Distance.

1. Position the handlebar straight ahead.
2. Turn the adjustment knob **C** to achieve the proper lever distance from the handlebar for the rider to reach the lever comfortably and ensure proper clutch engagement.

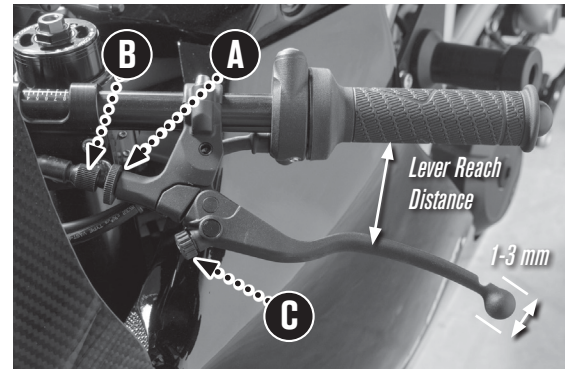

Front Brake Lever Response and Travel Distance

Adjusting Front Braking Response

1. Use the adjustment knob **D** to set desired brake response behavior.
 - N = Soft, liner braking
 - S = Sporty braking
 - R = Hard, direct braking

Adjusting Front Brake Lever Braking Ratio

1. Remove the protection cap **E**.
Turn the setting screw to the desired braking ratio.
 - 18 = Longer brake lever travel, soft response, and less lever force. Red indicator visible **G**.
 - 20 = Less brake lever travel, hard response, and more lever force. Black indicator visible.
1. Replace the protection cap **E**.

Adjusting Front Brake Lever Reach Distance

1. Position the handlebar straight ahead.
2. Turn the adjustment knob **F** to achieve the proper lever distance from the handlebar for the rider to reach the lever comfortably and ensure proper brake engagement.

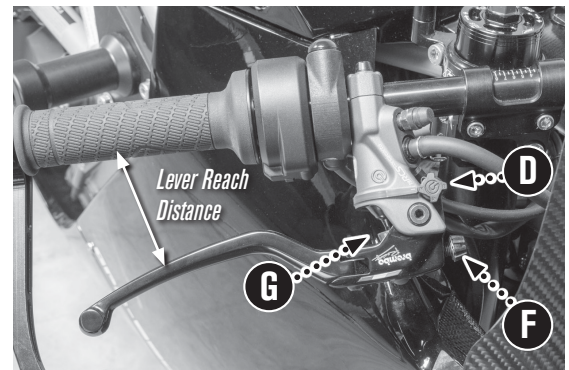

Front Braking Response and Lever Reach Distance Adjusting Knobs



Front Braking Lever Ratio Adjustment Screw

Rearset Setup

The adjustable rearset allows a personalized setting for each rider, with both foot pegs, the shift lever, and the brake lever being adjustable.

Adjusting the Foot Pegs

Right Side

1. Remove the exhaust muffler retainer springs **A**.
2. Loosen the nuts **B**.
3. Loosen the bottom screw **D** of the foot peg carrier.
4. Loosen and remove the top screw **C** so that the carrier can move freely.
5. Position the carrier to the desired location.
6. Apply blue thread lock* and tighten the top screw **C** to the appropriate torque – 25 Nm (18.4 ft-lb).
7. Apply blue thread lock* and tighten the bottom screw **D** to the appropriate torque – 25 Nm (18.4 ft-lb).
8. Tighten the nuts **B** to the appropriate torque – 25 Nm (18.4 ft-lb).
9. Reinstall the exhaust muffler retainer springs **A**.

Left Side

1. Loosen the bottom screw **F** of the foot peg carrier.
2. Loosen and remove the top screw **E** so that the carrier can move freely.
3. Position the carrier to the desired location.
4. Install, apply blue thread lock* and tighten the top screw **E** to the appropriate torque – 25 Nm (18.4 ft-lb).
5. Install, apply blue thread lock* and tighten the bottom screw **F** to the appropriate torque – 25 Nm (18.4 ft-lb).
6. Adjust the position of the shift and brake levers [See below].

* Loctite® 243™

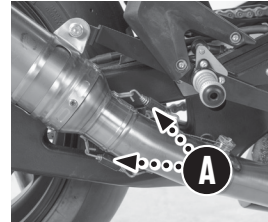

R.H. Side Rearset Adjustment Preparation

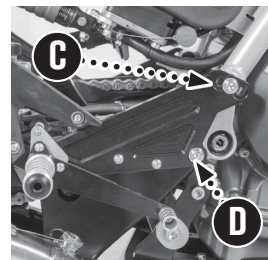
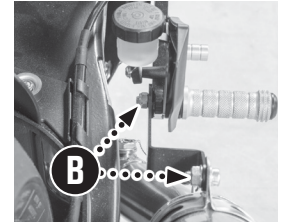

R.H. Side Rearset Adjustment

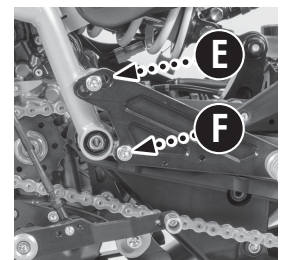

L.H. Side Rearset Adjustment

Rear Brake Lever Adjustment

Rear Brake Lever Adjustment

1. Loosen the brake rod jam nut **G**.
2. Adjust the length of the brake rod **H** by screwing the rod end bearing in or out of the brake rod until the brake lever is in the desired position.
3. Tighten the jam nut **G**.

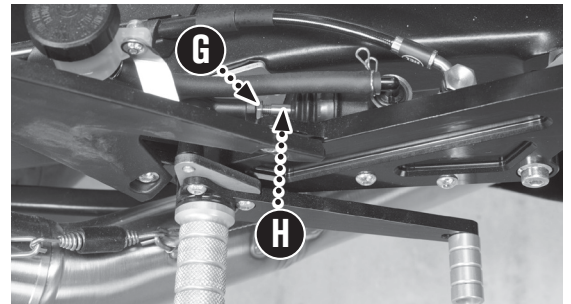

Brake Lever Adjustment – R.H. Side

Shift Lever Height Adjustment

Adjust the shift lever height by changing the shift linkage length.

1. Hold the shift shaft linkage **J** with a wrench and loosen the jam nuts **I** and **K** with a second wrench.
2. Adjust the length of the shift shaft linkage by rotating the shaft.
3. Adjust until the shift lever is in the desired position. Keep a minimum of 8mm of thread inside the linkage rod ends.
4. Tighten the jam nuts **I** and **K** to the appropriate torque – 10 Nm (7.4 ft-lb).

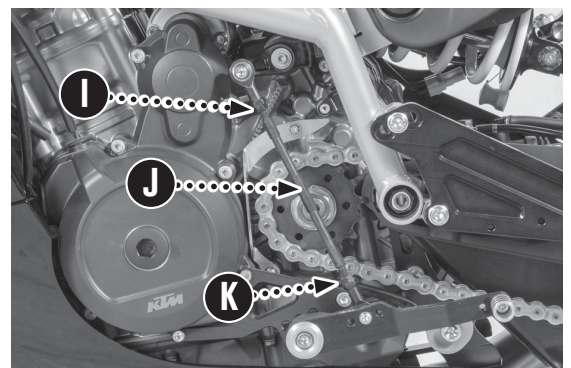

Brake System

WARNING! Danger of accidents

Reduced braking efficiency can be caused by worn brake pads.

- Check the brake pads regularly.
- Change worn brake pads immediately.



NOTE: If the brake pads are not changed in time, the steel brake pads carriers grind on the brake disc. The braking effect is greatly reduced and the brake discs are rendered unserviceable.

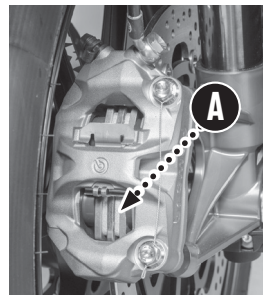

Front Brake Calipers

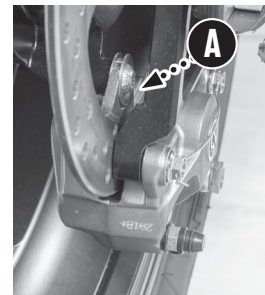

Rear Brake Calipers

Brake Inspection

Brake Pads

1. Visually inspect the brake pads for wear, cracking, and damage on all brake calipers **A**.
2. Ensure they have the minimum thickness.

Minimum thickness 1 mm
(≥ 0.04 in)

If the minimum thickness is less than specified or damage is found, change the brake pads.

Brake Discs

1. Check the thickness of the brake disc in several places to see if it is within the specified wear tolerance.

Wear Limit

Front ≥ 4.5 mm (≥ 0.18 in)

Rear ≥ 4 mm (≥ 0.16 in)

If the brake disc thickness is less than the specified value, change the brake discs.



USE ONLY DOT 5.1 Brake Fluid
from a new closed container

Brake Lines and Master Cylinders

1. Visually inspect the brake lines and master cylinders for leaking and cracking. Replace components if necessary.

Brake Fluid Level

Checking/Adding Front Brake Fluid Level

1. Remove the brake fluid reservoir mounting screw **B**.
2. Position the brake fluid reservoir to a horizontal position.
3. Check that the fluid level is between the MIN and MAX markings. Add DOT 5.1 brake fluid to the MAX level.
4. Remount the brake fluid reservoir.



Front Brake Disc

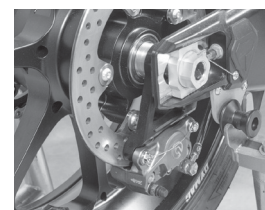

Rear Brake Disc



Front Fluid Reservoir



Rear Fluid Reservoir

Checking/Adding Rear Brake Fluid Level

1. Position the motorcycle on rear lift stand.
2. Check that the fluid level is between the MIN and MAX markings. Add DOT 5.1 brake fluid to the MAX level.

Brake Bleeding

Bleeding Front Brake Calipers

Use standard manual or vacuum bleeding procedures to bleed the front brake calipers.

SPECIAL NOTES:

- Bleed each caliper individually using the bleed screw **C**.
- Bleed brake lever at the bleed screw **D**.

Bleeding Rear Brake Caliper

Use standard manual or vacuum bleeding procedures to bleed the brake caliper.

SPECIAL NOTES:

- Remove the rear brake caliper and invert with the bleed screw **E** facing up.
- Raise the caliper to a position where the bleed screw is higher than the master cylinder.
- Place a 6 mm Allen wrench between brake pads to simulate the brake disc.
- Bleed the caliper using standard procedure.
- Remove the Allen wrench and install the caliper back on the motorcycle.

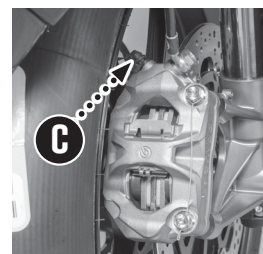

Front Caliper Bleed Screw

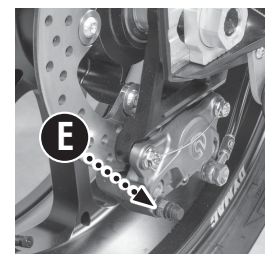

Rear Caliper Bleed Screw

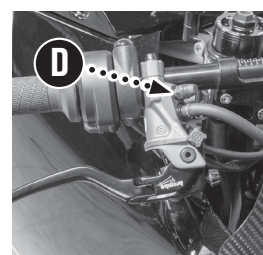

Brake Lever Bleed Screw

Changing the Brake Pads

Front Brake Calipers

1. Position the motorcycle on a rear lift stand.
2. Position the brake reservoir in a horizontal position. Remove from the mount if needed. Remove brake reservoir cap and membrane.
3. Manually press the brake caliper against the brake disc to retract the caliper piston. Monitor that the fluid in the reservoir doesn't overflow. Remove some if necessary.
4. Remove the locking safety wire **A**.
5. Remove mounting bolts **B**.
6. Remove calipers and spacers from mounts.
7. Remove brake pads **C** from calipers.
8. Clean the brake calipers.
9. Install the new brake pads. Check that the springs is correctly seated.
10. Position calipers and spacers in place and install mounting bolts **B**, but do not tighten them yet.
11. Squeeze the brake lever until brake pads contact the brake disc and there is firm resistance on the lever. Secure the lever in an active position. Check that the brake caliper is straight and aligned.
12. Apply white grease** and tighten the mounting bolts **B** to the appropriate torque – 45 Nm (33.2 ft-lb)
13. Rewire the locking safety wire.
14. If needed, fill the brake fluid level to the MAX line, secure the cap, and remount the brake reservoir.

* Loctite® 243™ ** White lithium grease

! **USE ONLY DOT 5.1 Brake Fluid from a new closed container**

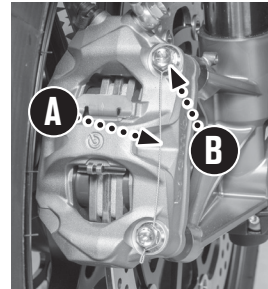

Front Brake Calipers

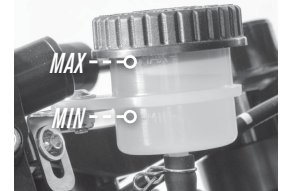
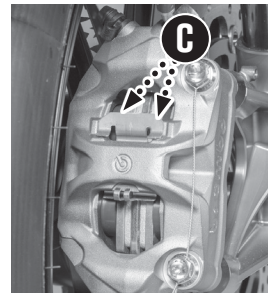

Front Brake Reservoir

Rear Brake Caliper

1. Position the motorcycle on a rear lift stand.
2. Remove the locking safety wire **E**.
3. Remove mounting bolts **D**.
4. Remove brake reservoir cap and membrane.
5. Manually press the brake caliper against the brake disc to retract the caliper piston. Monitor that the fluid in the reservoir doesn't overflow. Remove some if necessary.
6. Remove the retaining clip **H**.
7. Remove pin **G**.
8. Remove brake pads **F** and retaining springs.
9. Clean the brake caliper.
10. Install the new brake pads with retaining spring.
11. Replace pin **G** and retaining clip **H**.
12. Position the caliper, apply white grease**, install mounting bolts **D**, and tighten to the appropriate torque – 20 Nm (14.8 ft-lb)
13. Rewire the locking safety wire **E**.
14. Press the brake pedal until brake pads contact the brake disc and there is firm resistance on the pedal.
15. If needed, fill brake fluid level to the MAX line.

* Loctite® 243™ ** White lithium grease

! **USE ONLY DOT 5.1 Brake Fluid from a new closed container**

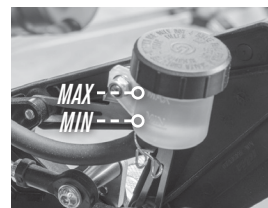

Rear Brake Reservoir

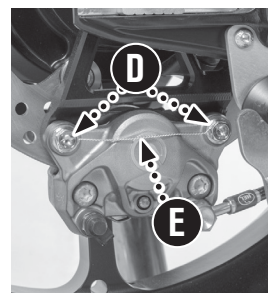

Rear Brake Caliper

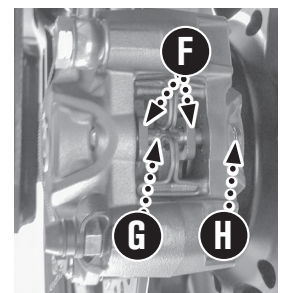

Suspension

Suspension Inspection

Front Forks

1. Check the full action of the forks by applying the front brake, pushing down on the handlebars, and compressing the forks several times.
2. Inspect the entire fork assembly for leaks, damage, or loose parts and fasteners.
3. Replace or repair any damaged components.
4. Tighten nuts and bolts to proper torque spec. [See "Chassis Torque Chart" on page 30]

Rear Suspension

5. Check the full action of the shock absorber by compressing it several times.
6. Inspect the shock absorber assembly for leaks, damage, or loose parts and fasteners.
7. Replace or repair any damaged components.
8. Tighten nuts and bolts to proper torque spec. [(See pg. 29)]

Swingarm

9. Raise the rear wheel off the ground and support the motorcycle securely.
10. Check for worn swingarm bearings by grabbing the swingarm and attempting to move it side to side.
11. Replace the bearings if any looseness is detected.

Checking the Steering Head Bearing Play

1. Raise the motorcycle under the frame, lifting the front wheel off the ground.
2. Remove the front fairing. [See pg. 13]
3. Unbolt steering damper from the top triple clamp **E**.
4. Position the handlebars in the straight-ahead position.
5. Grab the lower fork legs, and push and pull in a forward and rearward direction.
6. If play is detected, adjust the steering head play [See below]
7. Move the handlebar over the entire steering range. If any roughness or notching is detected, replace the headset bearings.
8. Install and torque the steering damper bolt to the top triple clamp **E** - 20 Nm (14.8 ft-lb).
9. Reassemble the front fairing. [See pg. 13]

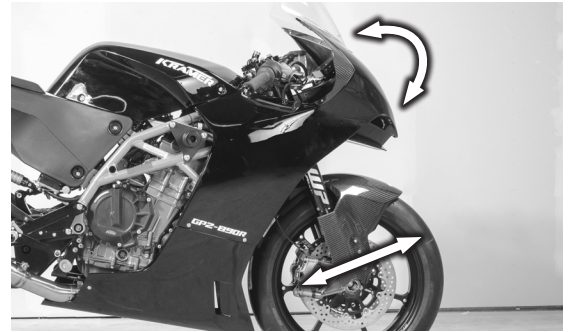

Adjusting the Steering Head Bearing Play

1. Position the motorcycle on a rear lift stand.
2. Remove the front fairing. [See pg. 13]
3. Unbolt steering damper from the top triple clamp **E**.
4. Loosen the top clamp bolts **A**.
5. Remove the top yoke bolt **B**.
6. Loosen the counter screw **C** and the steering stem adjusting nut **D**.
7. Tighten the steering stem adjusting nut **D** to a torque spec of 18 Nm (13.3 lb-ft).
8. Use a plastic hammer to tap lightly on the upper triple clamp.
9. Reinstall bolt **B** and torque to 15 Nm (11.1 ft-lb).
10. Tighten bolts **A** to appropriate torque of 15 Nm (11.1 ft-lb).
11. Check for smooth bearing operation with no free play.
12. Tighten the counter screw **C** to appropriate torque of 20 Nm (14.8 ft-lb).
13. Install and torque the steering damper bolt to the top triple clamp **E** - 20 Nm (14.8 ft-lb).
14. Reassemble the front fairing. [See pg. 13]

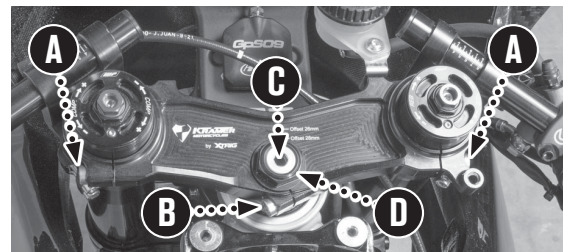

Changing the Fork Offset

1. Raise the motorcycle under the frame, lifting the front wheel off the ground.
2. Unbolt steering damper screws **A**.
3. Temporarily disconnect the damper from the frame.
4. Loosen the four bottom clamp screws **C**. (Two on each side.)
5. Loosen the two top clamp screws **D**. (One on each side.)
6. Loosen the top yoke screw **E**.
7. Remove the screws **F** and the screw **G**, and the lift stand pin bracket.
8. Remove the screws **H** on the lower triple clamp.
9. Separate the lower triple clamp from the conical shaft tube by temporarily installing the screw **G** into the hole **I**. Slowly tighten the screw **G**, pushing down the lower triple clamp.
10. Push the lower triple clamp down approx. 22 mm (0.86 in.), making sure the fork is not compressed in this state.
11. Make sure you do not loosen the counter screw **K**, use a 8 mm (Allen) wrench to turn it 180° in a clockwise direction, changing the head angle offset from one setting to the other.
12. Remove the screw **G** from the hole **I** and push up the lower triple clamp to the original position. Apply blue thread lock*, install the two screws **H** back in their original holes, and tighten - 20 Nm (14.8 ft-lb).
13. Position the lift stand pin bracket, install screws **F** and screw **G**, Apply thread lock,* and tighten to 10 Nm (7.4 ft-lb).
14. Tighten the four bottom clamp screws **C** - 15 Nm (11.1 ft-lb).
15. Tighten the two top clamp screws **D** - 15 Nm (11.1 ft-lb).
16. Tighten the top yoke screw **E** - 20 Nm (14.8 ft-lb).
17. Install steering damper bracket. Apply blue thread lock* and tighten screws **A** - 10 Nm (7.4 ft-lb).
18. Install steering damper to top triple clamp. torque screw **B** - 20 Nm (14.8 ft-lb).
19. Check the steering head bearing clearance and readjust if necessary.

* Loctite® 243™

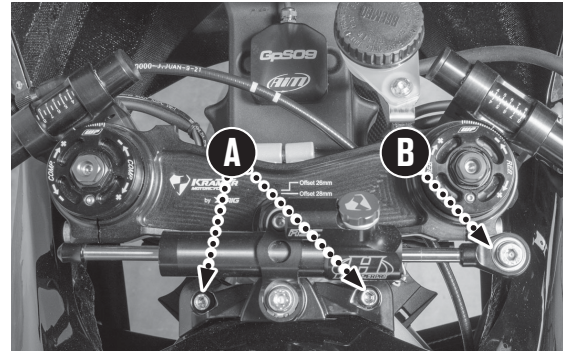

Steering Damper Screws

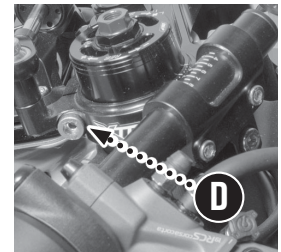
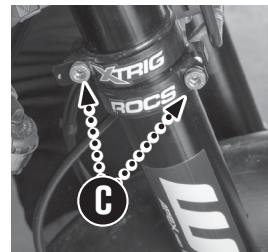

Top and Bottom Clamp Screws

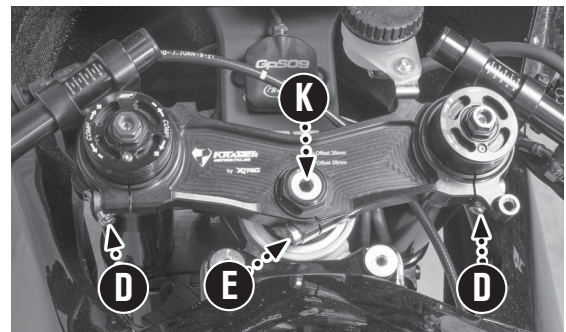

Adjustable Triple Clamp Top Yoke Screw and Stem Adjusting Nut

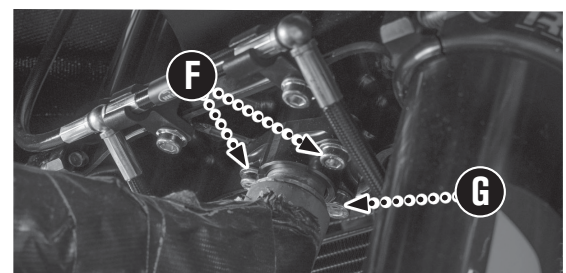

Bottom Stem Screws

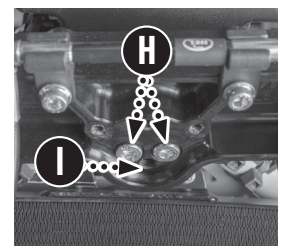
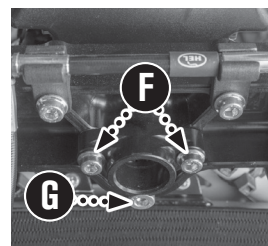

Bottom view of lower triple clamp and steering stem.

Fork Suspension Settings

Adjusting Spring Preload

Preload: The distance the spring is compressed from its free length with the suspension fully extended. It affects the suspension sag.

1. On the top of both fork tubes, turn the hex adjuster **A** equally to the desired setting. Be careful not to loosen the screw caps **B**.
2. **Zeroing:** Turn the screw as far as possible in a counterclockwise direction.

3. Turn the screw counterclockwise to desired setting.

Initial Guideline:

COMFORT – 16 clicks
STANDARD – 18 clicks
SPORT – 22 clicks

Turning clockwise increases the preload.; turning counterclockwise decreases the preload.

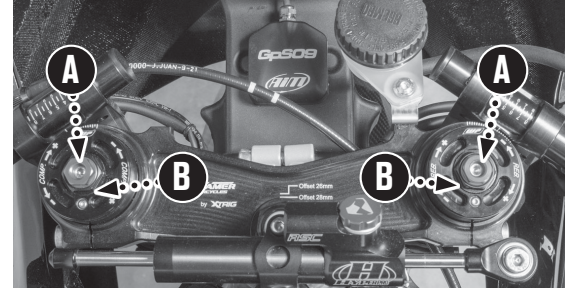

Fork Spring Preload

Adjusting Compression Damping

Compression damping: It controls the rate of suspension compression.

1. On the top of the left fork tube, turn the brass screw **C** to the desired setting.
2. **Zeroing:** Turn the screw as far as possible in a clockwise direction.
3. Turn the screw as many clicks as necessary counterclockwise to the desired setting.

Initial Guideline:

COMFORT – 20 clicks
STANDARD – 16 clicks
SPORT – 12 clicks

Turning clockwise increases the compression damping.; turning counterclockwise decreases the compression damping.

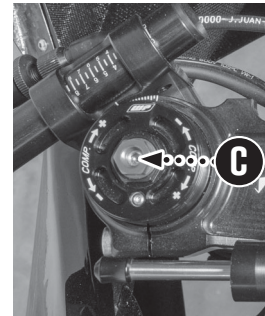

Compression Dampening (left fork)

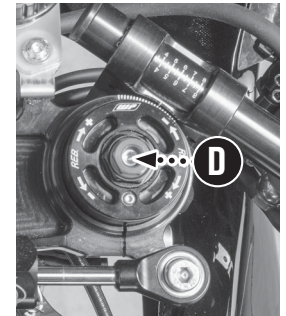

Rebound Dampening (right fork)

Adjusting Rebound Damping

Rebound damping: It controls the rate of suspension extension after compression, known as rebound.

1. On the top of the right fork tubes, turn the brass screw **D** to the desired setting.
2. **Zeroing:** Turn the screw as far as possible in a clockwise direction.
3. Turn the screw as many clicks as necessary counterclockwise to the desired setting.

Initial Guideline:

COMFORT – 18 clicks
STANDARD – 16 clicks
SPORT – 12 clicks

Turning clockwise increases the rebound damping.; turning counterclockwise decreases the rebound damping.

Fork Specifications

Fork	WP Suspension APEX PRO 7543
Spring length with preload spacer(s)	260 mm (10.24 in)
Spring Rate (Rider Weight)	
65-75 kg (143-165 lb.)	8.5 N/mm (48.5 lb/in)
75-85 kg (165-187 lb.)	9 N/mm (51 lb/in)
85-95 kg (187-209 lb.)	9.5 N/mm (54.2 lb/in)
Fork length	735 mm (28.94 in)

Rear Shock Suspension Settings

Adjusting the Spring Preload

Preload: It affects the suspension sag. The adjustment knob is on the right hand side under the seat.

1. Increase the spring preload by turning the preload knob clockwise.
2. Reduce the spring preload by turning the preload knob counterclockwise.

Initial Guideline:
STANDARD – 12mm (0.47in)

Adjusting Compression Damping

Compression damping: It controls the rate of suspension compression.

There are two separate setups, "High-Speed" and "Low-Speed". This refers to the speed at which the rear shock is being compressed.

Compression damping screws are accessed through the oval window on the left side of the motorcycle below the tank.

Low-Speed Compression Damping

1. Turn the BOTTOM adjusting screw **D** to desired setting. Take care to not loosen the cap **E**.
2. **Zeroing:** Turn the adjusting screw clockwise until it stops.
3. Turn the screw as many clicks as necessary counterclockwise to the desired setting.

Initial Guideline:
STANDARD – 18 clicks
Turning clockwise increases the compression damping; turning counterclockwise reduces the compression damping.

High-Speed Compression Damping

1. Turn the TOP adjusting screw **B** to desired setting. Take care to not loosen the cap **C**.
2. **Zeroing:** Turn adjusting screw counterclockwise until it stops.
3. Turn the screw clockwise as many clicks as necessary to the desired setting.

Initial Guideline:
STANDARD – 22 clicks
Turning clockwise increases the compression damping; turning counterclockwise reduces the compression damping.

Adjusting Rebound Damping

Rebound damping: It controls the rate of suspension extension after compression, known as rebound.

1. Turn the Rebound damping screw **F** on the left side of the shock, clockwise until it stops.
2. **Zeroing:** Turn the screw clockwise up to the last perceptible click.
3. Turn the screw counterclockwise as many clicks as necessary to the desired setting.

Initial Guideline:
STANDARD – 14 clicks

Turning clockwise increases the rebound damping; turning counterclockwise reduces the rebound damping.

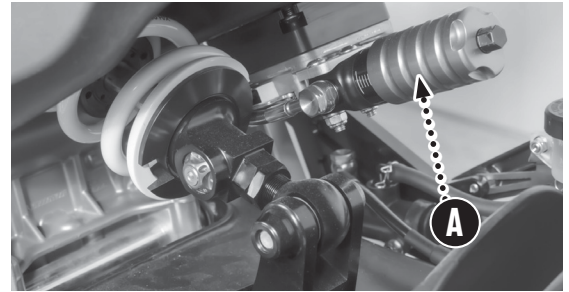

Spring Preload Adjuster

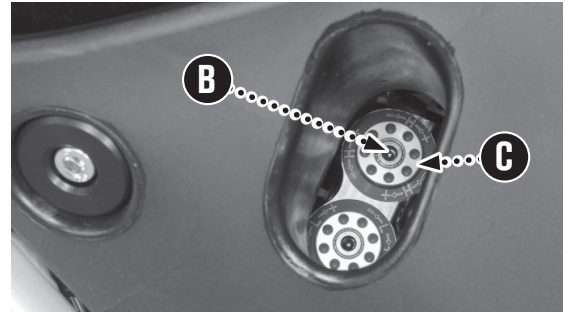

High-Speed Compression Adjusting Screw

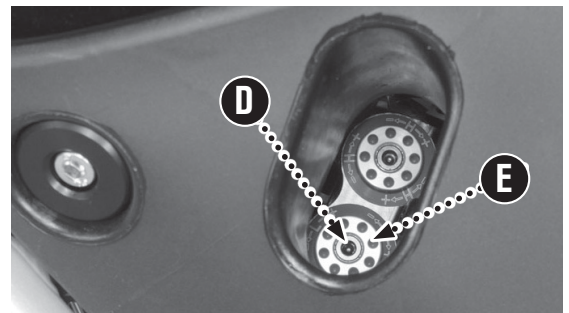

Low-Speed Compression Adjusting Screw

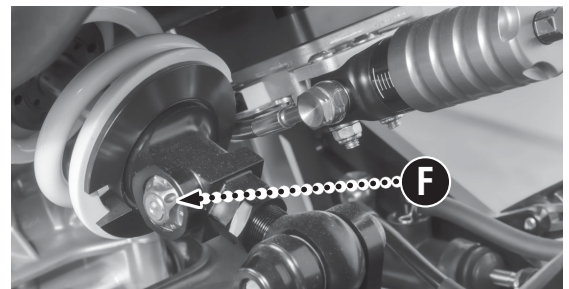

Rebound Damping Screw

Shock Absorber Specifications

Shock Absorber	WP Suspension APEX PRO 7746
Spring Length	130 mm (5.12 in)
Gas Pressure	10 bar (145 psi)
Fitted Length	299 mm (11.77 in)
Spring Rate (Rider Weight)	
55-65 kg (121-143 lb.)	80 N/mm (457 lb/in)
65-75 kg (143-165 lb.)	82 N/mm (468 lb/in)
75-85 kg (165-187 lb.)	84 N/mm (480 lb/in)
85-95 kg (187-209 lb.)	86 N/mm (491 lb/in)
95-105 kg (209-231 lb.)	88 N/mm (502 lb/in)

Wheels

Front Wheel Removal

1. Raise the motorcycle front and rear on lift stands. [(See pg. 7)]
2. Remove the front fender [(See pg. 13)]
3. Loosen the pinch bolts **B** on both front forks.
4. Unscrew the axle nut **C** about six turns and pull the axle out of the axle clamp. While holding the front wheel, withdraw the wheel spindle.
5. Take the front wheel out of the fork and swing the brake calipers outward.

WARNING! Danger of accidents
Damage brake discs reduce braking.



NOTE: Don't lay the wheel down on the brake disc as it can cause surface damage or bend the disc.

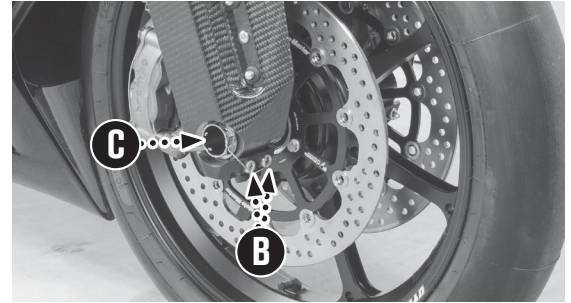

Front Wheel Axle and Pinch Bolts

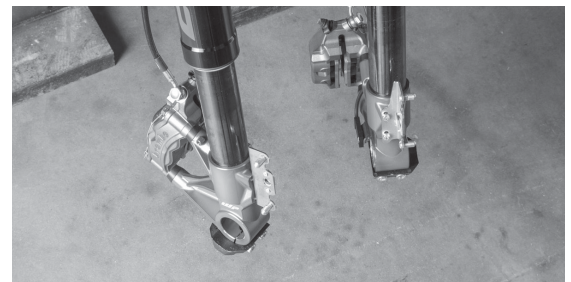

Calipers swing out for wheel removal

Front Wheel Installation

1. Clean, inspect, and grease the shaft seals.
2. Clean and grease the thread of the axle **C**.
3. Apply a thin film of grease on the axle for ease of installation.
4. Lift the front wheel, position it between the fork lowers, fold in the brake calipers, move the wheel rearward while sliding the brake discs into the calipers, and insert the axle through the forks and the wheel.
5. Screw the axle **C** into place and tighten to 60 Nm (44.3 lb-ft).
 - Safety wire as necessary. [(See pg. 30)]
6. Operate the hand brake lever repeatedly until the brake pad lining presses up against the brake disc and there is a pressure point.
7. Lower the motorcycle off the lift stands.
8. Pull the front brake and compress the fork powerfully a few times. (Aligns the fork legs.)
9. Tighten the fork end pinch bolts **B** - 10 Nm (7.4 lb-ft).
10. Install the front fender [(See pg. 13)]

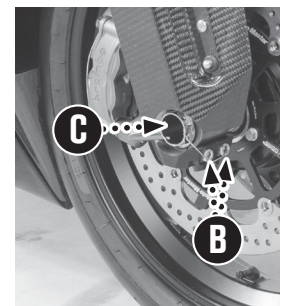
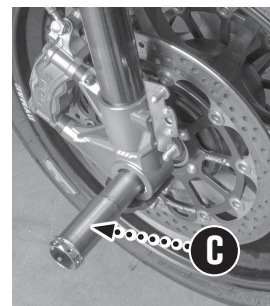
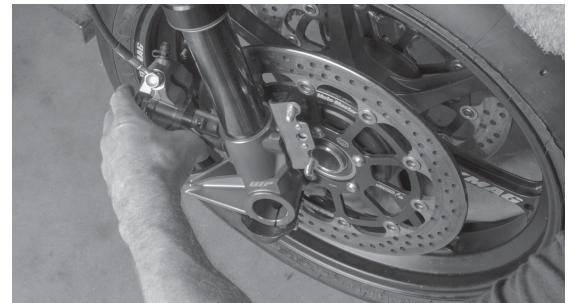

Rear Wheel Removal

1. Raise the motorcycle front and rear on lift stands. [(See pg. 7)]
2. Remove the axle nut **A** and the chain adjuster block **C**.
3. Hold the rear wheel and remove the axle **B**.
4. The wheel will rest on the retention system of the swingarm.
5. Move the rim forward in the swingarm to remove the chain from the sprocket.
6. Lift the rim until the brake disc is no longer between the caliper.
7. Tilt the tire slightly to ensure it does not hit the caliper when removing it.

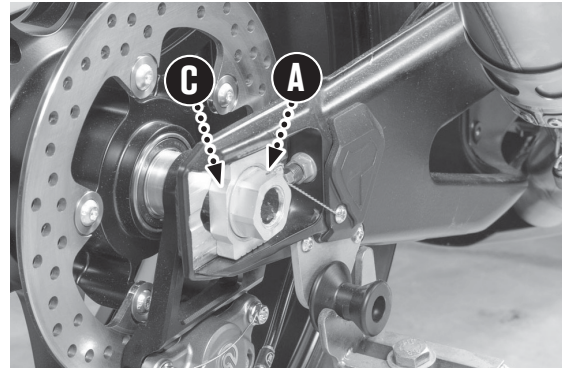

Rear Wheel Installation

1. Clean and grease the shaft seals and mating surfaces of the spacer.
2. Clean and grease the thread of the axle **B** and nut.
3. Clean the mating surfaces of the brake caliper support and swingarm.
4. Slightly tilt the rear tire to ensure it does not knock or damage the brake caliper when inserted into the swingarm.
5. Straighten the rim and lower it until the brake disc is inside the caliper.
6. The rim does not have to be supported, as it rests on the brake caliper.
7. Move the rim forward and place a part of the chain on top of the sprocket.
8. Rotate the tire backward until the chain is mounted back on the sprocket correctly.
9. Pull the tire back until it is realigned with the chain adjusters.
10. Insert the axle **B** from the left.
11. Attach the right adjuster block **C** and the axle nut **A** (loosely tightened).
12. Push the tire forward until the adjuster blocks are touching the adjuster screws.
13. Check the chain tension and adjust it if necessary. [(See pg. 9)]
14. Tighten the axle nut – 100 Nm (73.7 lb-ft).
15. Activate the rear brake several times to ensure there are no faults in the system.

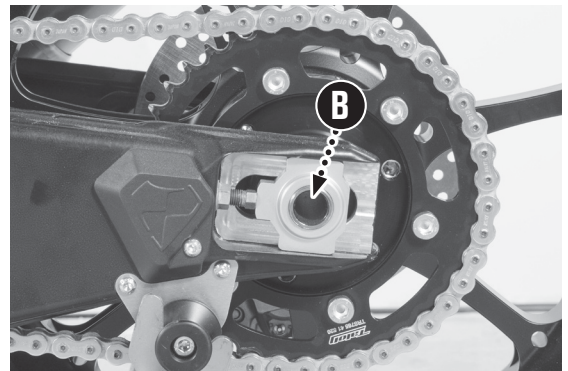

Electrical

Tail light Operation

Switching On

1. Press and hold the tail light lens **G** to power on.

Switching Off

2. Press and hold the tail light lens **G** until it powers off.

Changing Modes

3. Press the tail light lens **G** briefly to select one of the light modes— quick flashing, slow flashing, and constant on.

Charging the Tail light

1. Rotate tail light bezel counterclockwise to remove the tail light from the mount.
2. Plug a the mini-USB cable into the connector **H** to charge for a couple hours. Do not overcharge.
3. Install by placing the tail light in position and rotating it clockwise.

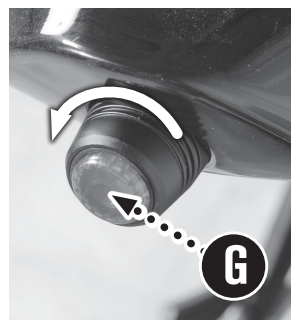

Electrical

Fuses

- The **Fuse Box** **A** is located on the left side of the motorcycle, above the battery. It contains three 10 amp fuses and a 5 amp fuse, plus space for 2 spare fuses.

Fuse 1 - 10A Ignition Switch

Fuse 2 - 10A Power Relay

Fuse 3 - 10A Fuel Pump

Fuse 4 - 5A ACC2

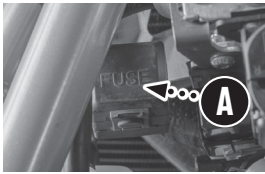

Fuse Box with Cover Open

- A **30 amp main fuse** **B** is on the starter solenoid, located behind the right side of the steering head.

Changing fuse

1. Turn off power/ignition switch.
2. Remove the intake cover/air filter box. [(See pg. 14)]
3. The fuse is located under the front dust cap at **B**. A spare fuse is located under the rear dust cap at **C**.
4. Replace faulty fuse, place dust caps in place, and install the air filter box cover.

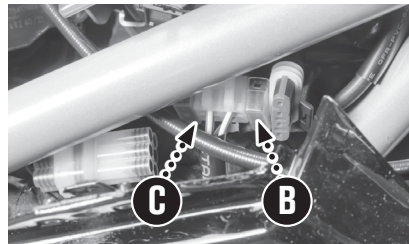

Main Fuse on Starter Solenoid

Powered Accessory Leads

Two 12-volt powered accessory leads **G**, which are protected by a 5 amp fuse, are provided. They are located on the right hand side under the air filter box.

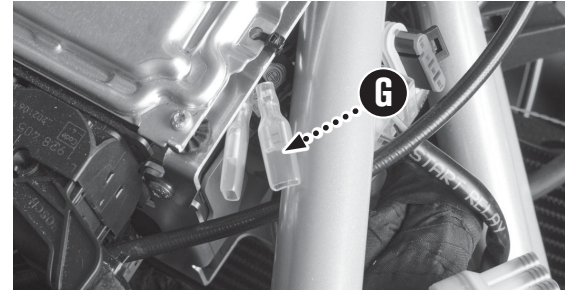

Battery

Location

The 12-volt battery is found under the intake cover/air filter box behind the steering head.

Charging

Use a proper lithium rated battery charger. (Optimate 12.8/13.4 V .8 amp charger is recommended.)

BATTERY INFO

Krämer Motorcycles are factory-equipped with a lightweight **LITHIUM BATTERY**

- Part No: 301153000
- 12.8 V / 4 Ah

Use a proper lithium rated battery charger to ensure long life.

Removal/Installation

1. Turn off the power/ignition switch.
2. Remove the intake cover/air filter box. [(See pg. 14)]
3. Remove screws **D** and **E**. Remove the steering damper.
4. Remove cable tie.
5. Pull upward the engine control unit **F** and hang it to the side.
6. Remove fasteners **G**.
7. Remove mounting bracket **H**.
8. Detach negative cable **I**.
9. Detach positive cable **J**.
10. Lift out the battery.
11. Install in reverse order.

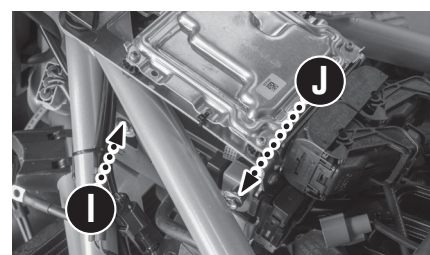
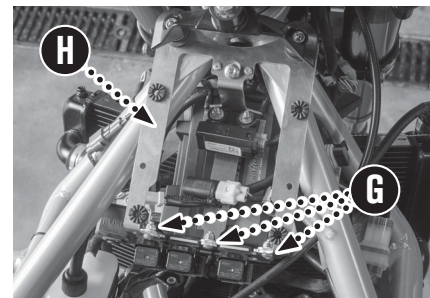
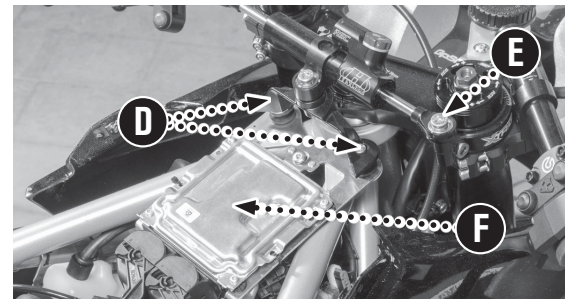

Technical Data

GP2 890-R Specifications

Frame	Trellis frame of steel tubes, powder-coated
Fork	WP Suspension APEX PRO 7543
Shock absorber	WP Suspension APEX PRO 7746
Brake system	
Front	Disc brake with 4-piston brake caliper
Rear	Disc brake with single-piston brake caliper, floating
Suspension travel	
Front	120 mm (4.72 in)
Rear	120 mm (4.72 in)
Brake discs - diameter	
Front	290 mm (11.42 in)
Rear	230 mm (9.06 in)
Brake discs - wear limit	
Front	4.5 mm (0.177 in)
Rear	4.0 mm (0.157 in)
Tire pressure (warm)	
Front: 75–85 °C (167–185 °F)	2.21 bar (32 psi)
Rear: 75 ... 85 °C (167 ... 185 °F)	1.65 bar (24 psi)
Secondary ratio	16:41
Chain	5/8" x 1/4" (520)
Steering head angle	66.7°
Wheelbase	1,400 ± 15 mm (55.12 ± 0.59 in)
Seat height, unloaded	820 mm (32.28 in)
Ground clearance, unloaded	150 mm (5.91 in)
Weight without fuel, approx.	140 kg (309 lb.)
Maximum permissible front axle load	160 kg (353 lb.)
Maximum permissible rear axle load	270 kg (595 lb.)
Maximum permissible overall weight	430 kg (948 lb.)

Engine Specifications

Design	2-cylinder parallel-twin 4-stroke engine, water-cooled	
Displacement	890 cm ³ (54.31 cu in)	
Stroke	68.8 mm (2.709 in)	
Bore	90.7 mm (3.571 in)	
Compression ratio	13.5:1	
Idle speed	2,300 ± 50 rpm	
Control	DOHC, 4 valves per cylinder controlled via cam lever, chain drive	
Valve diameter, intake	37 mm (1.46 in)	
Valve diameter, exhaust	30 mm (1.18 in)	
Valve play, cold		
Intake at: 20°C (68 °F)	0.10 – 0.15 mm (0.0039 – 0.0059 in)	
Exhaust at: 20°C (68 °F)	0.15 – 0.20 mm (0.0059 – 0.0079 in)	
Crankshaft bearing	Slide bearing	
Connecting rod bearing	Slide bearing	
Piston pin bearing	Piston pin with bronze coating	
Pistons	Forged light alloy	
Piston rings	1 compression ring, 1 lower compression ring, 1 oil ring with spring expander	
Engine lubrication	Semi-dry sump lubrication system with two trochoid pumps	
Primary transmission	39:75	
Clutch	Slipper clutch in oil bath/mechanically operated	
Transmission	6-gear transmission, claw shifted	
Transmission ratio		
First gear	13:37	
Second gear	17:34	
Third gear	20:31	
Fourth gear	22:28	
Fifth gear	24:26	
Sixth gear	23:22	
Alternator	12 V, 400 W	
Ignition	Contactless controlled fully electronic ignition with digital ignition adjustment	
Spark plug	NGK LMAR9AI-10	
Spark plug electrode gap	1.0 mm (0.039 in)	
Cooling	Water cooling, permanent circulation of coolant by water pump	
Starting	Electric starter	

Fluid Capacities

Engine oil	2.8 L (3 qt) SAE 15W/50
Coolant	1.6 L (1.8 qt) Engine Ice Hi-Performance
Brake Fluid	DOT 5.1
Fork Oil	SAE 5, Volume: 500 ml, Air space: 150 mm Motorex Racing Fork Oil
Fuel Tank Capacity, (approx.)	16 L (4.2 US gal) Super unleaded (ROZ 98 / RON 98 / PON 94)

Electrical System

12 V battery	LTM14-B	Lithium-ion battery
		Battery voltage: 12.8 V
		Nominal capacity: 4.0 Ah
	Maintenance-free	
Fuse	75011088005	5A
Fuse	75011088010	10A
Fuse	75011088030	30A
Tail light	LED	

Engine Torque Chart

Water Pump Drain Hole Plug	EJOTALtracs® Plus 60x14	8 Nm (5.9 ft-lb)*	
Bleeder Flange Screw	EEJOTALtracs® 6x12	8 Nm (5.9 ft-lb)*	
Hose Clamp, Intake Flange	M4	2.5 Nm (1.84 ft-lb)	
Nozzle, Engine Vent	M5	2 Nm (1.5 ft-lb)	
Oil Nozzle for Piston Cooling	M5	2 Nm (1.5 ft-lb)	
Oil Nozzle in Cylinder Head	M5	2 Nm (1.5 ft-lb)	
Remaining Screws, Engine	M5	6 Nm (4.4 ft-lb)	
Cam Lever Axial Lock Screw	M5	6 Nm (4.4 ft-lb)*	
Crankshaft Speed Sensor Screw	M5	6 Nm (4.4 ft-lb)*	
Gear Position Sensor Screw	M5	6 Nm (4.4 ft-lb)*	
Oil Filter Cover Screw	M5	6 Nm (4.4 ft-lb)	
Pressure Plate Screw	M5	3 Nm (2.2 ft-lb)*	
Shift Drum Retaining Bracket Screw	M5	6 Nm (4.4 ft-lb)*	
Shift Shaft Sensor Screw	M5	6 Nm (4.4 ft-lb)*	
Thermostat Case Screw	M5	6 Nm (4.4 ft-lb)*	
Balancer Shaft Securing Screw	M5	5 Nm (3.7 ft-lb)*	
Swing Angle Sensor Screw	M5	6 Nm (4.4 ft-lb)*	
Starter Motor Cable Nut	M6	5 Nm (3.7 ft-lb)	
Engine Remaining M6 Screws	M6	10 Nm (7.4 ft-lb)	
Alternator Cover Screw	M6x30	10 Nm (7.4 ft-lb)	
Alternator Cover Screw	M6x35	10 Nm (7.4 ft-lb)	
Camshaft Bearing Bridge Screw	M6	10 Nm (7.4 ft-lb)	
Clutch Cable Retaining Bracket Screw	M6	10 Nm (7.4 ft-lb)*	
Clutch Cover Screw	M6	10 Nm (7.4 ft-lb)	
Clutch Release Lever Screw	M6	10 Nm (7.4 ft-lb)*	
Clutch Spring Screw	M6	10 Nm (7.4 ft-lb)	
Cylinder Head Screw	M6	10 Nm (7.4 ft-lb)	
Engine Case Screw	M6x30	12 Nm (8.9 ft-lb)	
Engine Case Screw	M6x60	12 Nm (8.9 ft-lb)	
Freewheel Ring Screw	M6	14 Nm (10.3 ft-lb)*	
Ignition Coil Screw	M6	8 Nm (5.9 ft-lb)	
Locking Lever Screw	M6	10 Nm (7.4 ft-lb)*	
Main Shaft Bearing Support Screw	M6	10 Nm (7.4 ft-lb)*	
Oil Pan Screw	M6x30	10 Nm (7.4 ft-lb)	
Oil Pan Screw	M6x35	10 Nm (7.4 ft-lb)	
Oil Pump Cover Screw	M6	10 Nm (7.4 ft-lb)*	
Oil Pump Unit Screw	M6	10 Nm (7.4 ft-lb)	
Oil/Water Heat Exchanger Screw	M6	10 Nm (7.4 ft-lb)*	
Shift Drum Locating Screw	M6	10 Nm (7.4 ft-lb)*	
Shift Lever Screw	M6	14 Nm (10.3 ft-lb)*	
Shift Shaft Retaining Bracket Screw	M6	10 Nm (7.4 ft-lb)*	
Starter Motor Screw	M6	10 Nm (7.4 ft-lb)	
Stator Screw	M6	10 Nm (7.4 ft-lb)*	
Timing Chain Shaft Screw	M6	10 Nm (7.4 ft-lb)	
Upper Guide Rail Screw	M6	8 Nm (5.9 ft-lb)*	
Valve Cover Screw	M6	10 Nm (7.4 ft-lb)	
Water Pump Cover	M6	10 Nm (7.4 ft-lb)*	
Water Pump Wheel	M6	10 Nm (7.4 ft-lb)*	
Nut, Exhaust Flange	M8	15 Nm (11.1 ft-lb)***	
Oil Nozzle for Clutch Lubrication	M8	5 Nm (3.7 ft-lb)*	
Remaining Screws for Engine	M8	20 Nm (14.8 ft-lb)	
Screw Plug, Locking Screw	M8	15 Nm (11.1 ft-lb)	
Engine Case Screw	M8x45	25 Nm (18.4 ft-lb) †	
Engine Case Screw	M8x55	25 Nm (18.4 ft-lb) †	
Engine Case Screw	M8x65	25 Nm (18.4 ft-lb) †	
Engine Case Screw	M8x90	25 Nm (18.4 ft-lb) †	
Knock Sensor Screw	M8	20 Nm (14.8 ft-lb)	
Oil Pump Idler Gear Screw	M8	15 Nm (11.1 ft-lb)*	
Tensioning Rail Screw	M8	15 Nm (11.1 ft-lb)*	
Stud, Exhaust Flange Stud	M8	15 Nm (11.1 ft-lb) *	
Connecting Rod Bearing Screw	M8x0.75	1st stage 5 Nm (3.7 ft-lb) 2nd stage 20 Nm (14.8 ft-lb) 3rd stage goo Screw support and thread oiled	
Spark Plug	M10	11 Nm (8.1 ft-lb)	
Oil Pressure Sensor	M10x1	10 Nm (7.4 ft-lb)	
Screw Plug, Bearing Support	M10x1	12 Nm (8.9 ft-lb)*	
Screw Plug, Cam Lever Axis	M10x1	8 Nm (5.9 ft-lb)	
Screw, Unlocking of Timing Chain Tensioner	M10x1	8 Nm (5.9 ft-lb)	
Coolant Temperature Sensor	M10x1.25	10 Nm (7.4 ft-lb)	
Cylinder Head Screw	M10x1.25	Tightening sequence: Observe tightening sequence. 1st stage - 5 Nm (3.7 ft-lb) 2nd stage - 15 Nm (11.1 ft-lb) 3rd stage - 90° 4th stage - 90° Screw support greased/thread oiled	
Screw Plug, Cylinder Head Oil Drain	M12x1.5	10 Nm (7.4 ft-lb)	
Screw, Rotor	M12x1.5	90 Nm (66.4 ft-lb) Thread greased	
Screw Plug, Water Jacket	M16x1.5	20 Nm (14.8 ft-lb)*	
Nut, Engine Sprocket	M20x1.5	120 Nm (88.5 ft-lb)*	
Nut, Inner Clutch Hub	M20x1.5	135 Nm (99.6 ft-lb)	
Plug, Oil Screen	M20x1.5	10 Nm (7.38 ft-lb)	
Plug, Timing Chain Tensioner	M24x1.5	25 Nm (18.4 ft-lb)	
Screw Plug, Alternator Cover	M24x1.5	8 Nm (5.9 ft-lb)	

* Loctite®243™

*** Copper paste

† Screw support greased

Chassis Torque Chart

Chassis Remaining M5 Nuts	M5	5 Nm (3.7 ft-lb)
Chassis Remaining M5 Screws	M5	5 Nm (3.7 ft-lb)
Chassis Remaining M6 Nuts	M6	10 Nm (7.4 ft-lb)
Chassis Remaining M6 Screws	M6	10 Nm (7.4 ft-lb)
Chassis Remaining M8 Screws	M8	25 Nm (18.4 ft-lb)
Chassis Remaining M10 Nuts	M10	45 Nm (33.2 ft-lb)
Chassis Remaining M10 Screws	M10	45 Nm (33.2 ft-lb)
Rear Brake Fluid Reservoir Screw	M5	5 Nm (3.7 ft-lb)*
Rear Brake Cylinder Screw	M6	10 Nm (7.4 ft-lb)*
Rear Brake Lever Screw	M6	15 Nm (11.1 lbf ft)*
Rear Brake Lever Stub Screw	M6	10 Nm (7.4 ft-lb)*
Rear Brake Caliper Screw	M8	20 Nm (14.8 ft-lb)**
Rear Brake Disc Screw	M8	25 Nm (18.4 ft-lb)*
Fuel Pump Screw	M6	6 Nm (4.4 ft-lb)
Handlebar Stub Clamp Screw	M6	10 Nm (7.4 ft-lb)
Handlebar Fork Tube Stub Clamp Screw	M6	15 Nm (11.1 t-lb)
Handlebar Stub Screw Clamping Piece on Handlebar Tube Screw	M8	20 Nm (14.8 ft-lb)
Shift Lever Stub Screw	M6	10 Nm (7.4 ft-lb)*
Shift Rod Screw	M6	12 Nm (8.9 ft-lb)*
Shift Rod Linkage Screw	M6	7 Nm (5.2 ft-lb)*
Shift Rod Screw	M8	20 Nm (14.8 ft-lb)*
Shift Shaft Support on Engine Screw	M8	20 Nm (14.8 ft-lb)*
Steering Damper Bracket Screw	M6	15 Nm (11.1 lbf ft)*
Lifting Gear Bracket Screws—front	M6	10 Nm (7.8 ft-lb)*
Lifting Gear Support Screw—Rear	M8	25 Nm (18.4 ft-lb)*
Footrest Bracket Screw	M8	25 Nm (18.4 ft-lb)*
Fork Stub Screw	M8	15 Nm (11.1 ft-lb)
Front Brake Disc Screw	M8	25 Nm (18.4 ft-lb)*
Front Brake Caliper Screw	M10x1.25	45 Nm (33.2 ft-lb)**
Fuel Tank Fastening Screw	M8	25 Nm (18.4 ft-lb)*
Main Silencer Clamp Screw	M8	18 Nm (13.3 ft-lb)
Steering Damper Bracket on Console Screw	M8	10 Nm (7.4 ft-lb)*
Steering Damper on Triple Clamp Screw	M8	20 Nm (14.8 ft-lb)*
Top Steering Stem Screw	M8	20 Nm (14.8 ft-lb)
Top Triple Clamp Screw	M8	15 Nm (11.1 ft-lb)
Bottom Triple Clamp Screw	M8	15 Nm (11.1 ft-lb)
Banjo Bolt, Brake Line	M10	25 Nm (18.4 ft-lb)
Rear Sprocket Bolt	M10	50 Nm (36.9 ft-lb)*
Deflection Console on Engine Screw	M10	25 Nm (18.4 ft-lb)
Engine Brace on Engine Screw	M10	30 Nm (22.1 ft-lb)*
Engine Brace on Frame Screw	M10	30 Nm (22.1 ft-lb)*
Linkage Lever on Angle Lever Screw	M10	45 Nm (33.2 ft-lb)*
Bottom Shock Absorber Screw	M10x1.25	45 Nm (33.2 ft-lb)*
Top Shock Absorber Screw	M10x1.25	45 Nm (33.2 ft-lb)*
Tension Strut Bearing Screw	M12	45 Nm (33.2 ft-lb)*
Angle Lever to Link Fork Nut	M14	100 Nm (73.8 ft-lb)
Tension Strut on Angle Lever Nut	M14x1.5	100 Nm (73.8 ft-lb)
Swingarm Pivot Nut	M16x1	100 Nm (73.8 ft-lb)**
Steering Head, Top Nut	M25x1.5	18 Nm (13.3 ft-lb)
Rear Wheel Spindle Nut	M25x1.5	100 Nm (73.8 ft-lb)**
Front Wheel Spindle Screw	M29x1.5	60 Nm (44.3 ft-lb)**

* Loctite®243™

** Long-life white grease

Safety Wire

Safety wire is installed as an additional measure of protection to keep critical fasteners in place from hard use or vibration.

For your reference, here are the steps in order:

1. Drill fasteners or install ones with drilled heads.
2. Loop the wire through the fastener in a direction that pulling on the wire would tighten the fastener.
3. Twist with safety wire pliers (or needle-nose pliers - more labor-intensive, but it works).
4. Stop a little short of the next bolt or anchor point, and make the last twist by hand to get it to the perfect length.
5. Go into the opposite side of the other fastener.
6. Tighten up the second fastener with several twists.
7. Snip off end of pigtail and tuck in (snipped ends are needle-sharp, and if you don't tuck them in, they will snag or puncture your skin or gear!).
8. Collect snipped part and throw it in trash (if not, it becomes a needle waiting to pierce a tire if left on the ground!).

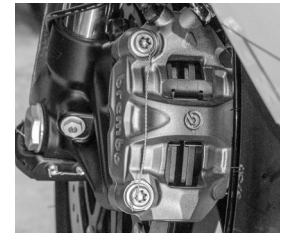
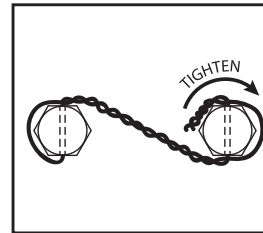

This illustration shows how proper safety wire is installed - in a manner that, if one bolt were to come loose, it would tighten the other, and vice versa.

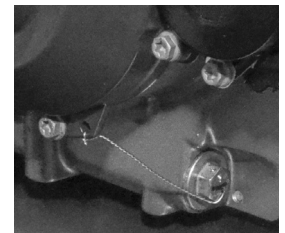
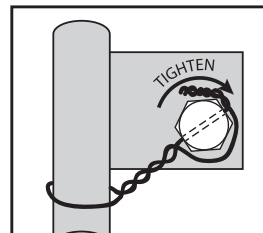

This illustration shows how proper safety wire is installed to a stationary part.

AIM Compact MXS 1.2 Dash Logger

The AIM Compact 5" Color TFT dash logger has been specifically configured for the Krämer GP2-890R motorcycle. It displays relevant data to the rider and logs data that can be retrieved and analyzed in the AIM Race Studio 3 software.

The indicator lamps offer additional information about the operating state of the motorcycle. When the ignition is switched on, all indicator lamps light up briefly.

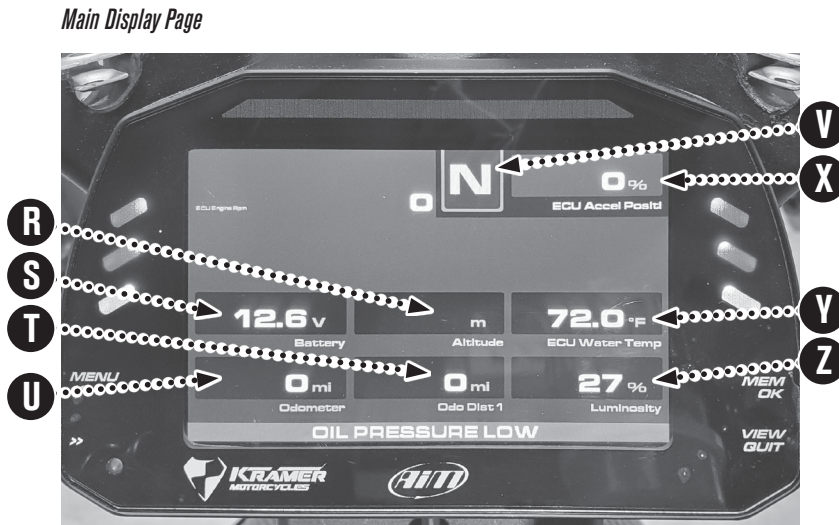
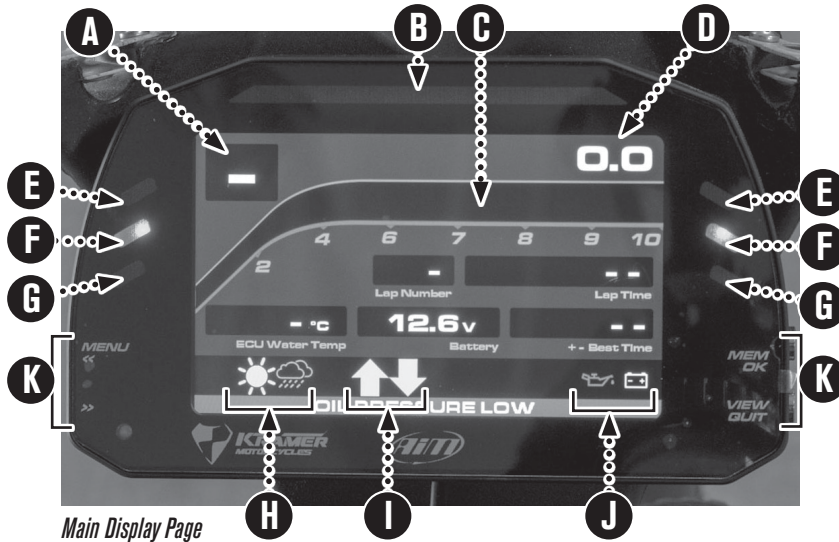

Dash Logger Indicators Overview

Main Display Page

- A** Gear Indicator
- B** Shift warning light
- C** Tachometer
- D** GPS Indicated Speed
- E** Coolant temperature warning lamp
 - lights up *blue* if coolant is <150°F (65°C),
 - lights up *red* if coolant is >221°F (105°C),
 - *flashes red* if coolant is >230°F (110°C).
- F** Oil pressure warning lights up red if the oil pressure warning lamp is active.
- G** Malfunction indicator lights up yellow if the engine indicator light is active.
- H** Throttle response setting (See pg. 15)
- I** Engine braking effect setting (See pg. 15)
- J** Operating status indicator lights
 - Charging
 - Oil Pressure
- K** Multi-function Menu buttons are used to enter and navigate the menu area of the dash logger.

- L** Battery Voltage Meter.
- M** Coolant Temperature.
- N** Low Oil Pressure light.
- O** Lap Number.
- P** Lap Time.
- Q** Best Lap Time.

Secondary Display Page

This page is displayed by pressing the **View/Quit** button once.

- R** Altitude
- S** Battery Voltage
- T** Odometer Distance 1
- U** Odometer
- V** Gear Indicator
- X** ECU Throttle Position (%)
- Y** ECU Water Temperature
- Z** The Display Brightness

Dash Logger Menu Configuration Settings

Using the **Multi-function Menu** buttons **K**, press the MENU button to display the sub-menus of the configuration page.

Press the NEXT and PREV buttons to navigate this page. Move to desired function setting, then press ENTER to open that setting's page.

Visit www.kramermotorcyclesusa.com/dash-logger for more info on the AIM Dash logger.



Set Date and Time



Date and Time

Here you can:

- **Set time and date format**
- **Synchronize the date and time** with the data supplied by the connected GPS. In this case, if a nearby racetrack is available and selected, the system will set the date and time of that racetrack. If no racetrack is selected, then the synchronization date and time will need to be set manually. The current time and date are displayed at the bottom of the page.

Set Backlight



Backlight

The **brightness of the display** and LEDs may be adjusted in two ways, depending on the light captured by a dedicated sensor integrated into the dash logger.

- **AUTOMATIC:** The brightness is dimmed if the ambient light is brighter than a defined threshold. You can set day and night brightness levels and the brightness threshold value that switches from day to night mode.
- **MANUAL:** You may choose the brightness of the display and LEDs: 20%, 40%, 60%, 80%, & 100%.

Set Video Input



Video In

Video In page manages up to two additional optional back cameras (which cannot be logged).

Features to set are:

- **Input:** Video 1 / Video 2
- **Format:** NTSC/PAL
- **Brightness and Contrast** from 10 to 100%

Use the CHANGE button to set each feature and the NEXT button to scroll the features.

The MXS 1.2 is compatible with the AIM SmartyCam models.

Lap Time Setup

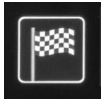

Lap Time Setup

The Lap Time **Predictive Reference** is selected on this page.

- Best Lap of Test
- Best Lap of Today
- Previous Lap

Counters Management



Counters

Four user odometers are displayed.

User 1 – User 4, plus a non-resettable System Odometer. All odometers are shown on the configuration software Race Studio 3 too.

Each odometer can be activated/deactivated and/or reset. To manage an odometer select it and press “CHANGE”.

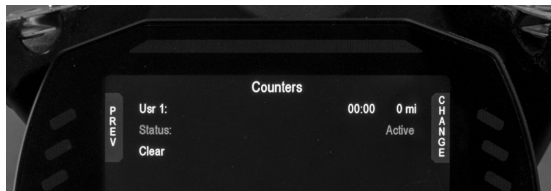

GPS & Tracks

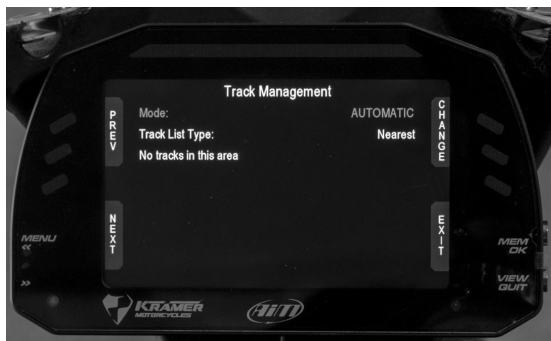

GPS & Tracks

The MXS 1.2 dash logger series provides two track selection modes: automatic and manual.

Automatic:

The dash logger automatically recognizes the racetrack you are riding on, loads the start/finish line and the possible splits coordinates, and calculates lap and split times without an optical/magnetic receiver. In most cases, this is the best mode.

Manual:

Manually select the track from the internal database. This mode is preferred when multiple track configurations are available nearby. In this case, the dash logger recognizes the racetrack but will need at least one complete track lap to synchronize.

You can scroll the list of available racetracks choosing among these options:

- **Nearest:** shows only tracks in a 10 km distance.
- **All:** shows all tracks stored in the system in alphabetical order.
- **Custom:** shows only the tracks you have previously created.

MXS series dash logger receives data on the racetrack from the AIM GPS09 Module. This module assists in the calculation of Lap Time, Speed, and Predictive Lap Time. The system needs to know the current racetrack's start/finish line coordinates. MX Strada series comes with a long list of tracks, constantly updated and loaded to your PC when you run Race Studio 3 software, and a connection to the Internet is available.

Wi-Fi Management



Wi-Fi

SSID Identification

When connecting to the unit's Wi-Fi signal, you can obtain the Wi-Fi SSID of a specific dash logger. Connecting directly to the dash logger with a PC gives the Race Studio 3 software direct access to retrieve the logged data and configure the MXS 1.2 dash logger.

Here you can manage the Wi-Fi settings, select the channel to be used (expert users only), and reset its configuration.

Wi-Fi modes are:

- ON
- AUTO: switches the Wi-Fi on when the vehicle is stopped and automatically switches it off when the dash logger starts recording according to the setting you performed on the "Parameters" page of Race Studio 3 software.
- OFF

Select Channel function is for expert users only. Select which Wi-Fi channel to use. Available options are:

- AUTO (default - recommended)
- 1
- 6
- 11

Wi-Fi reset CFG resets Wi-Fi configuration and is helpful if you forget your Wi-Fi password.

System Info



This page shows the system information of the MXS 1.2 dash logger displaying:

- Model Name
- Serial Number
- Firmware Version
- Boot Version
- And information of any attached devices.

GPS Search



Check the connection status of GPS satellites.

View with page by pressing the **View/Quit** button twice.

Sampled Data Recall

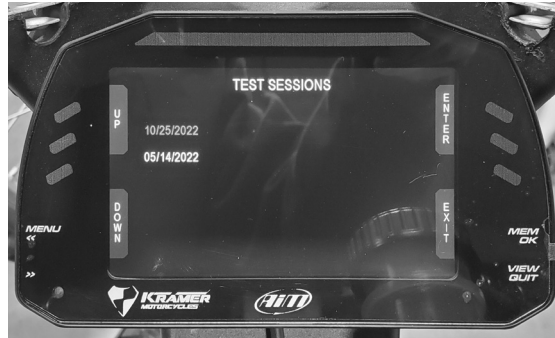

Test Sessions Summary

MXS 1.2 dash logger can show up to eight pages of sampled data.

The **Test Session Summary** of collected data is recalled by pressing the MEM/OK button.

- Select a desired date.
- The **Day Summary** page shows the tests with time of the test, number of laps, and best lap of the test. Select the desired test and press ENTER.
- The **Test Session** page shows specific information from the session.



Day Summary Page



Sample of Test Session information

Pit Limiter Indicator



Pit Limiter Indicator

This page displays when the motorcycle is in Pit Limiter mode.



KRAMER
MOTORCYCLES

Krämer Motorcycles U.S.A.,

SALES ▪ CUSTOMER SERVICE ▪ PARTS

114 1st Avenue West, West Fargo, ND, 58078

(701) 367-2258 www.kramermotorcyclesusa.com